

Höhenverstellbare
Rückseitenbearbeitungs-
Werkzeuge
**High adjustable
back working tools**
Porte-outils réversible
réglable en hauteur



INHALT
SUMMARY
SOMMAIRE

Grundhalter Basic holder Porte-outil de base.....	6
Zwischenstücke Plate between Entre plateau.....	8
Kühlmittelanschluss Connection for coolant supply Raccord pour canal d'arrosage.....	9
Innenbearbeitung / Internal processing	
Halter für Spannzangen Holder for collet chuck Porte-outils réversible pour pince de serrage ...	11
Halter für zylindrische Rundschaft-Werkzeuge Holder for cylindrical round shank tools Porte-outils réversible pour outils à queue cylindrique	14
Halter für HORN Schneidplatten Typ 105/110 Holder for HORN inserts type 105/110 Porte-outils réversible pour inserts HORN type 105/110	15
Halter für Holler Schneidplatten Holder for Holler inserts Porte-outils réversible pour inserts Holler	22

Halter für Picco Schneidplatten	
Holder for Picco inserts	
Porte-outils réversible pour inserts Picco	26

Halter für Simtec Schneidplatten	
Holder for Simtec inserts	
Porte-outils réversible pour inserts Simtec	30

Mehrfachbearbeitungshalter	
Multiple back working tools	
Multiple porte outils réversible	32

Kopierdrehen / Copy turning

Halter für / holder for / porte outils pour

Platte / insert DC	39
Platte / insert DC .. 11 T3	42
Platte / insert VB	48
Platte / insert VC.. 11 03	49
Platte / insert VC .. 13 03	56
Platte / insert VC .. 16 04	60
Platte / Insert VP .. 10 03	61

Langdrehen / turning

Halter für / holder for / porte outils pour

Platte / insert Applitec Typ 300	62
Platte / insert CC .. 06 02	65
Platte / insert CC .. 09 T3	67
Platte / insert TC	70
Platte / insert TN	72
Platte / insert TP	73

Formstechen / Gewindedrehen

Einstech-Langdrehen

Forming / grooving / turning/ threading

Halter für / holder for / porte outils pour

Platte / insert ER 16../EL 16..	74
Platte / insert HORN Typ 274	77
Einsatz für QER-12 (Quad-Cut).....	78
Platte / insert HORN Typ 312	80
Platte / insert SCD/CSX/CS/VP CS/TP CS 08..	86
Platte / insert GTMH 32.....	88
Platte / insert GRAF	
Typ G 02/G 03/G 04/TPG 05/VPG 05.....	89
Platte / insert APPLITEC Typ 700.....	90

Axialdrehen / Face grooving

Halter für / holder for / porte outils pour

Platte / insert DC .. 11 T3	92
Platte / insert VC .. 11 03	94
Platte / insert VC .. 13 03	96
Platte / insert SC .. 07 03	97

Sonderhalter

Special holder

Porte outil special.....	99
--------------------------	----

Höheneinstellvorrichtung HVR 40

Device for height adjusting HVR 40

Appareil de réglage en hauteur HVR 40	100
---	-----

Grundhalter G
Basic holder G
Porte-outil de base G

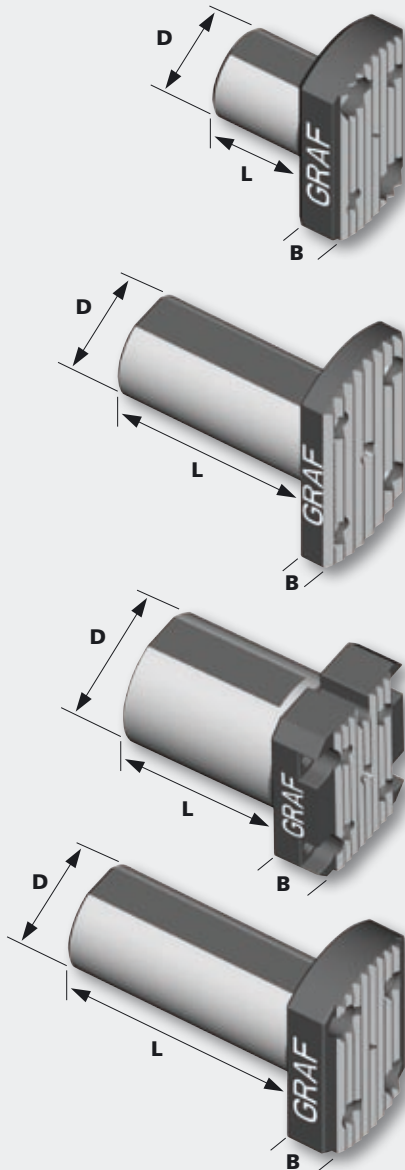

STAR-Maschinen

D	L	B	Best.-Nr.
16	10	10	G016 010 SW 7
16	19	10	G016 019 SW 7
16	21	6	G016 021
22	23	6	G022 023
22	30	6	G022 030
22	70	6	G022 070
22	25	12	G022 025 SR16/20R
22	25	12	G022 030 SR32
34	30	12	G034 030 ECAS 32

CITIZEN-Maschinen

D	L	B	Best.-Nr.
3/4"	40	6	G034 040
3/4"	50	6	G034 050
3/4"	120	6	G034 120
20	30	6	G020 030
1"	30	6	G010 030
1"	60	6	G010 060
1"	100	6	G010 100

MAIER-Maschinen

D	L	B	Best.-Nr.
28	40	12	G028 040
30	45	12	G030 045
34	20	12	G034 020
34	44	12	G034 044

TRAUB-Maschinen

D	L	B	Best.-Nr.
16	40	6	G016 040
28	80	12	G028 080

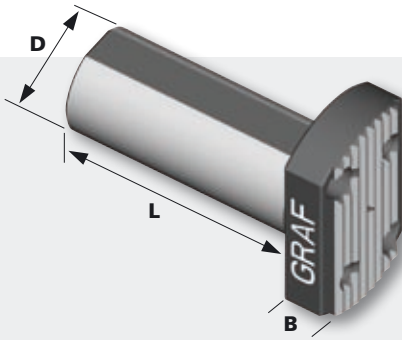

HANWHA-Maschinen

D	L	B	Best.-Nr.
20	40	6	G020 040
25	40	12	G025 040
25	60	12	G025 060
28	6	12	G028 006
32	25	12	G032 025
33	40	12	G033 040
34	44	12	G034 044

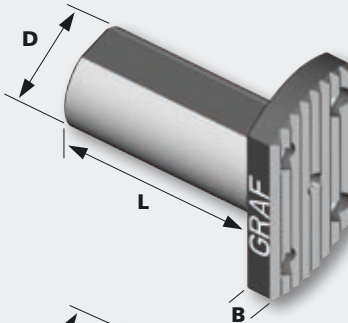

MANURHIN-Maschinen

D	L	B	Best.-Nr.
16	40	6	G016 040
20	150	6	G020 150
25	70	6	G025 070
25	100	6	G025 100
25	160	6	G025 160

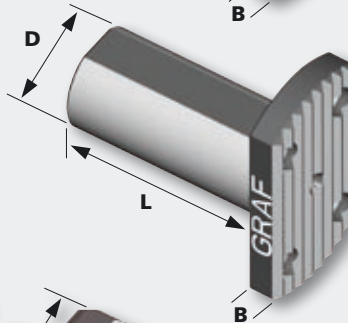

TORNOS-Maschinen

D	L	B	Best.-Nr.
20	100	6	G020 100
20	150	6	G020 150
25	70	6	G025 070
25	100	6	G025 100
25	160	6	G025 160

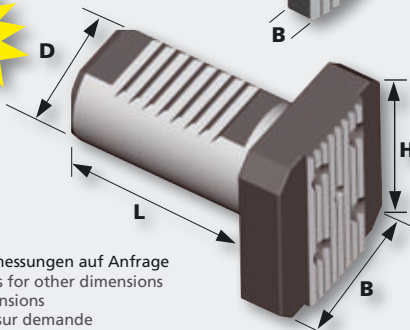

VDI-Aufnahmen

D	L	H	B	Best.-Nr.
16	32	45	24	GV016 032
20	40	45	24	GV020 040
25	48	50	35	GV025 048
30	55	52,5	45	GV030 055

weitere Abmessungen auf Anfrage
Please ask us for other dimensions
Autres dimensions
disponibles sur demande

Zwischenstücke
Plate between
Entre plateau

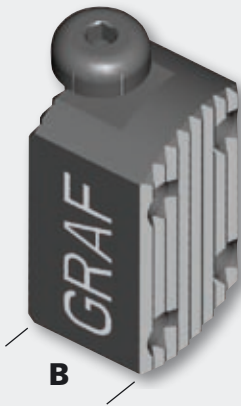

B	Best.-Nr.
5	Z5
10	Z10
15	Z15
20	Z20
25	Z25
30	Z30

B	Best.-Nr.
5	Z5 SR16/20R
10	Z10 SR16/20R
15	Z15 SR16/20R
20	Z20 SR16/20R
25	Z25 SR16/20R
30	Z30 SR16/20R

Für Grundhalter	G 022 025 SR16/20R
For basic holder	G 022 030 SR32
	G 025 060
Pour porte-outil de base	G 028 006
	G 028 040
	G 028 080
	G 032 25
	G 033 40

Kühlmittelanschluss Standard
connection for inner cooling
raccord à vis pour canal d'arrosage



Kühlmittelanschluss
004.00.19

für Rohr \varnothing 6 mm



Kühlmittelanschluss
004.00.22

für Rohr \varnothing 6 mm

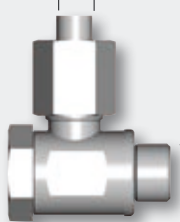

Schwenkverschraubung

M8 X 1 - 004.00.61
G1/8" - 004.00.16

Kühlmittelanschluss Schnellkupplung
Clip connection for inner cooling
Raccord à clip pour canal d'arrosage



Schnellkupplung 004.00.49

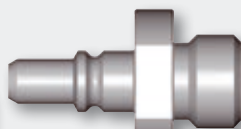

Stecker

M8 X 1 - 004.00.56
G1/8" - 004.00.57

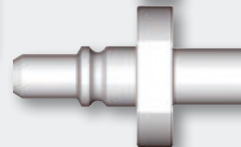

Stecker

\varnothing 6 mm - 004.00.59

GRAF-Einsätze jetzt auch „Überkopf“ höhenstellbar.

All GRAF insert cassettes can be mounted with the insert facing up or down and you can still adjust the center height.

Porte-outils GRAF-inversés disponibles aussi avec réglage en hauteur.

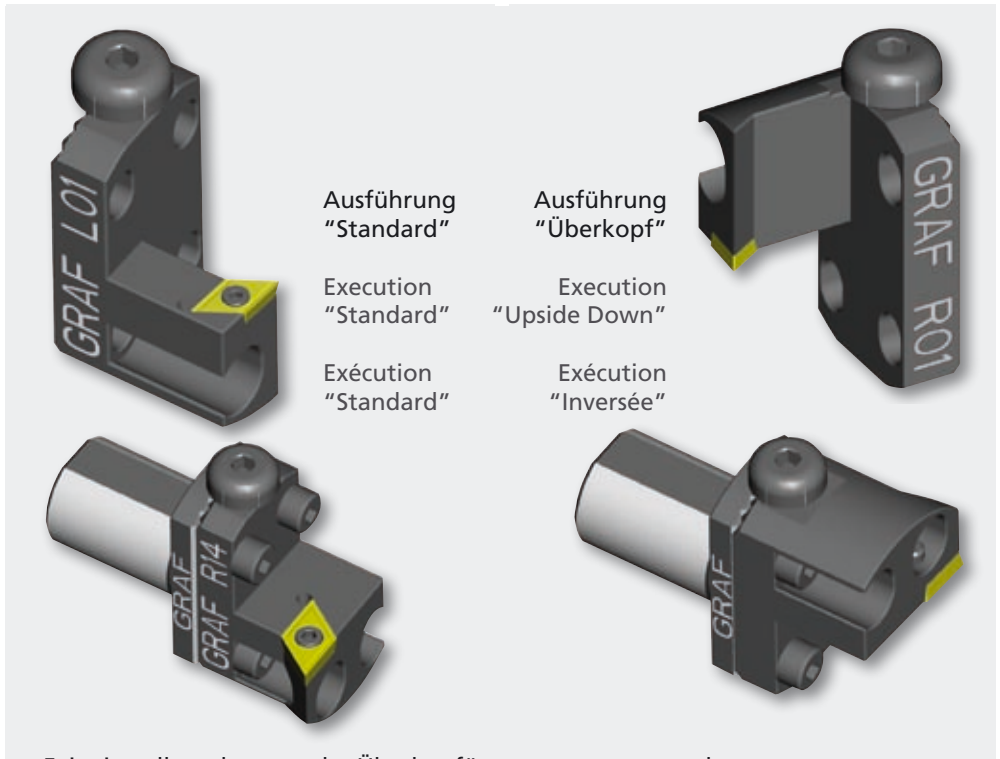

Feineinstellung kann auch „Überkopf“ vorgenommen werden. Bessere Späneabfuhr bei grobspanigem Material, z.B. bei langspanenden Werkstoffen wie Kunststoffe usw.

Fine adjustment is possible with the insert facing upside down for better chip evacuation. Especially for long stringy materials such as plastic.

Réglage fin aussi en position inversée. Meilleure évacuation des copeaux lors de l'ébauche ou de matières à copeaux longs.

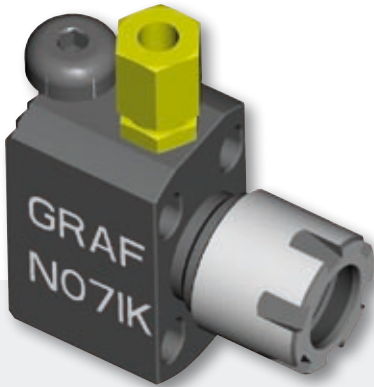

N07IK

Anwendungsbereich **Innenbearbeitung**
Range of application **internal processing**

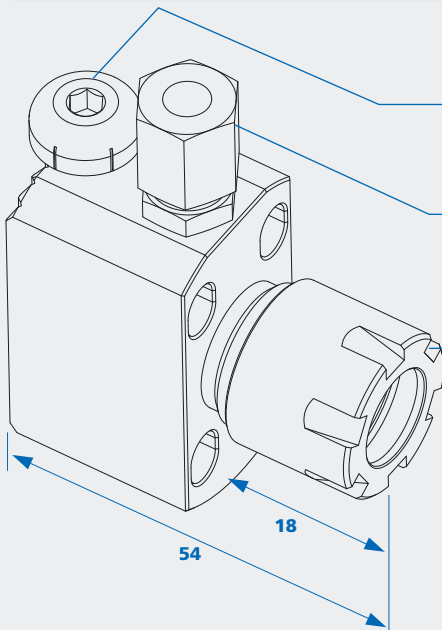

Höhenverstelle schraube
screw to adjust the height
vis pour régler la hauteur
002.00.69

Kühlmittelanschluss
Coolant supply
Connexion pour liquide
de refroidissement
004.00.19

Spannmutter ER 16 - abgedichtet
chucking nut - seal
écrou tendeur - étanche
62.600.16

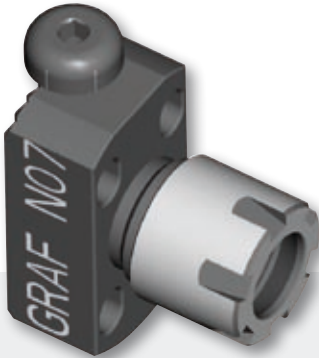

N07

Anwendungsbereich **Innenbearbeitung**
Range of application **internal processing**

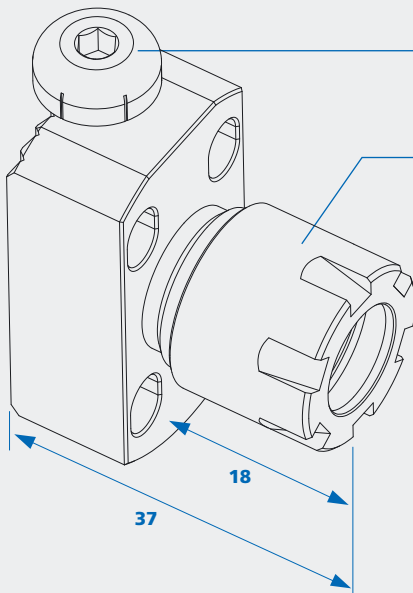

Höhenverstellungsschraube
screw to adjust the height
vis pour régler la hauteur
002.00.69

Spannmutter ER 16
chucking nut
écrou tendeur
62.000.16

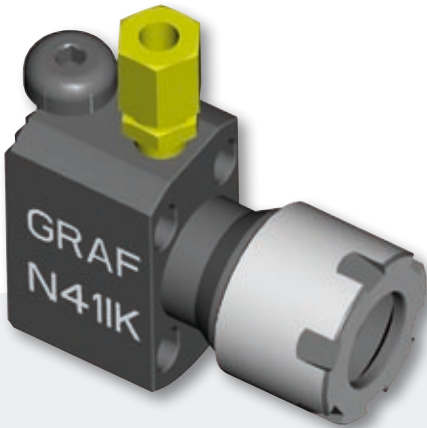

N41IK

Anwendungsbereich **Innenbearbeitung**
Range of application **internal processing**

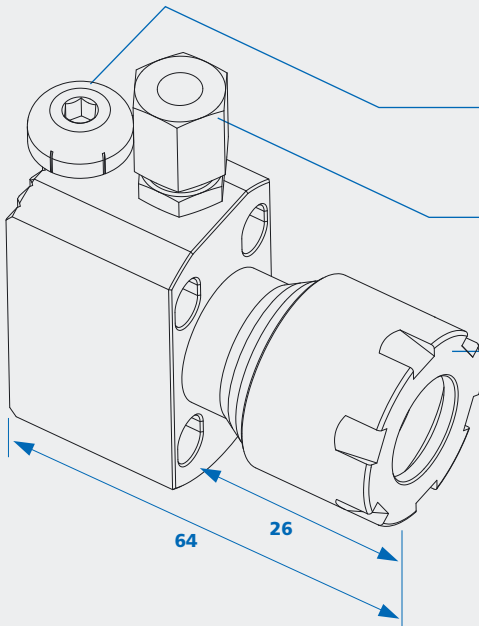

Höhenverstellungsschraube
screw to adjust the height
vis pour régler la hauteur
002.00.69

Kühlmittelanschluss
Coolant supply
Connexion pour liquide
de refroidissement
004.00.19

Spannmutter ER 20 - abgedichtet
chucking nut - seal
écrou tendeur - étanche
62.600.20



N30

Anwendungsbereich **Innenbearbeitung**
Range of application **internal processing**

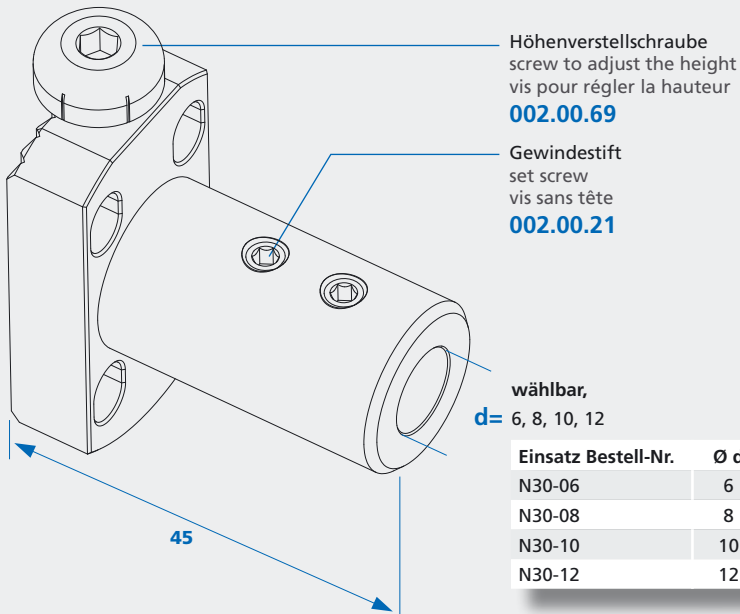

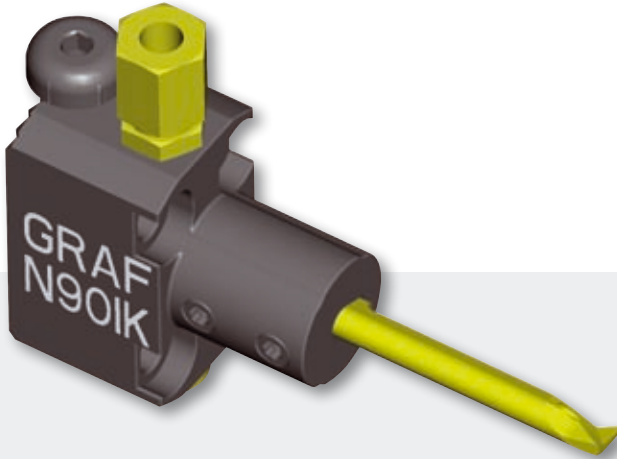

N90IK

Anwendungsbereich **Innenbearbeitung**
Range of application **internal processing**

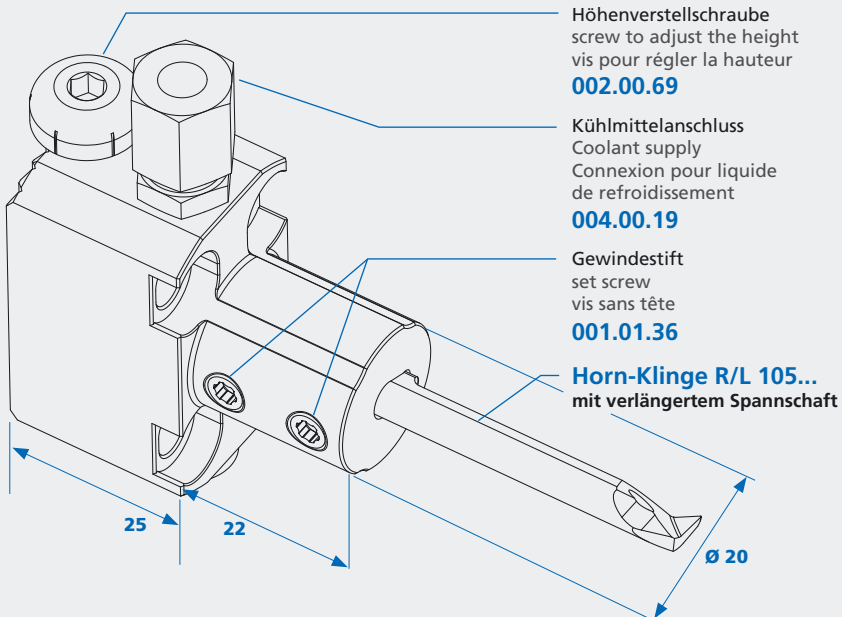

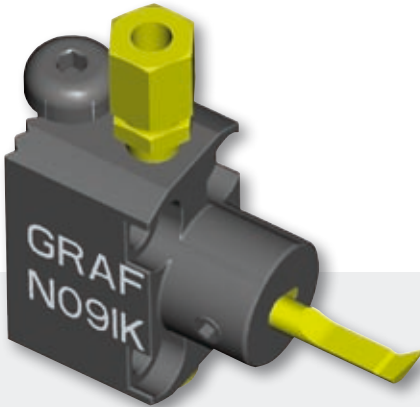

N091K

Anwendungsbereich **Innenbearbeitung**
Range of application **internal processing**

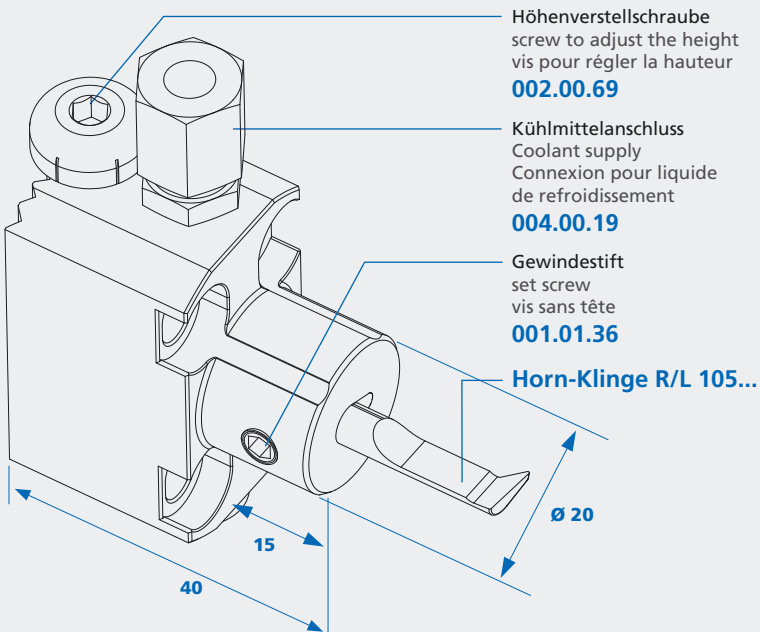

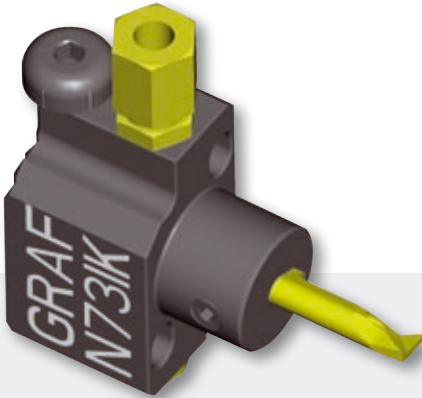

N73IK

Anwendungsbereich **Innenbearbeitung**
Range of application **internal processing**

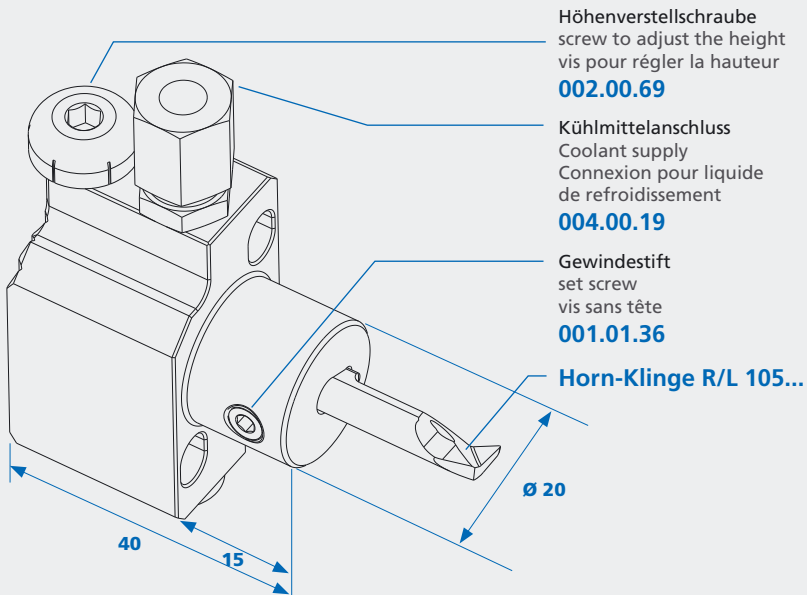

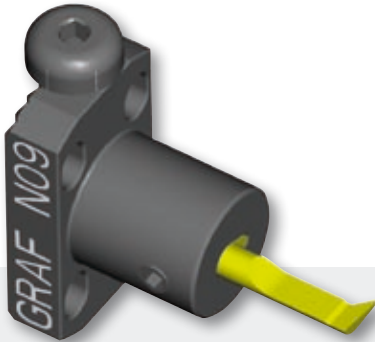

N09

Anwendungsbereich **Innenbearbeitung**
Range of application **internal processing**

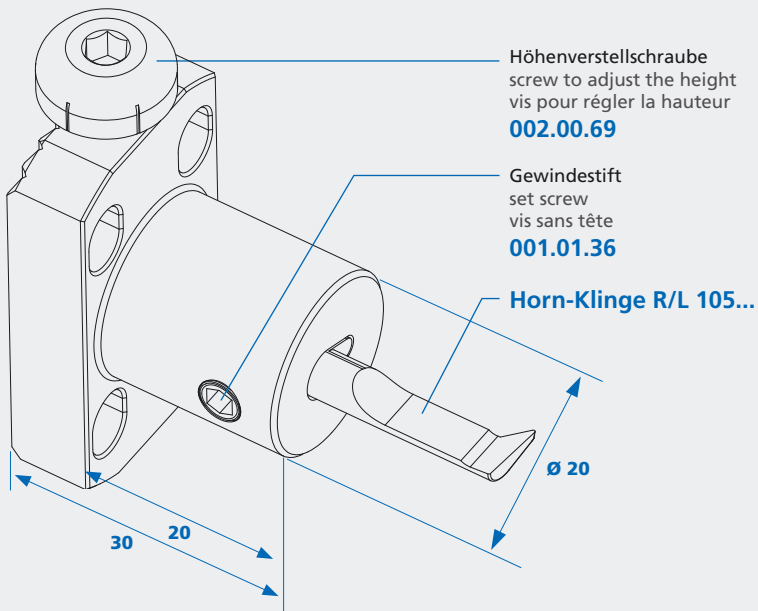

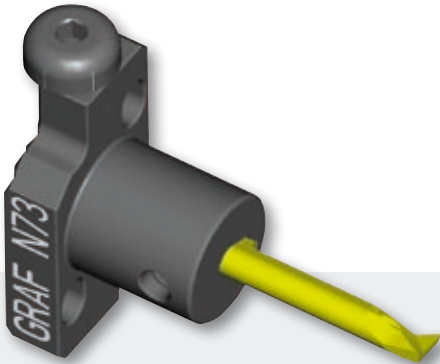

N73

Anwendungsbereich **Innenbearbeitung**
Range of application **internal processing**

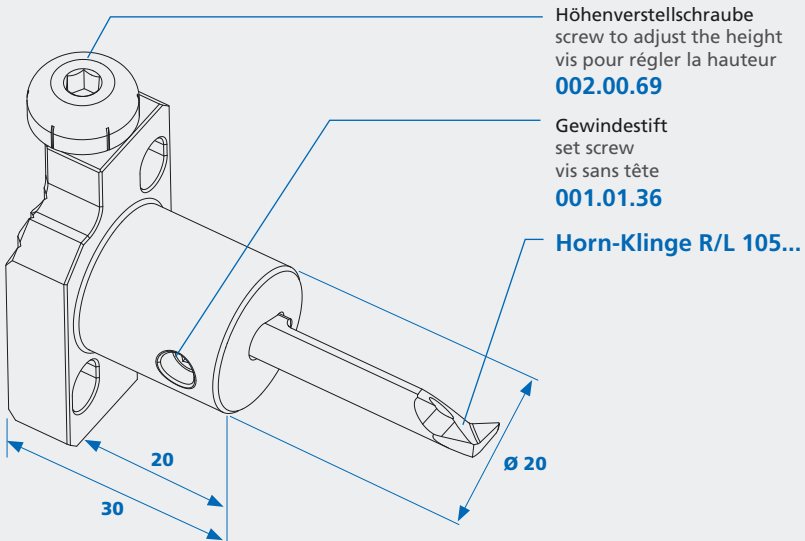

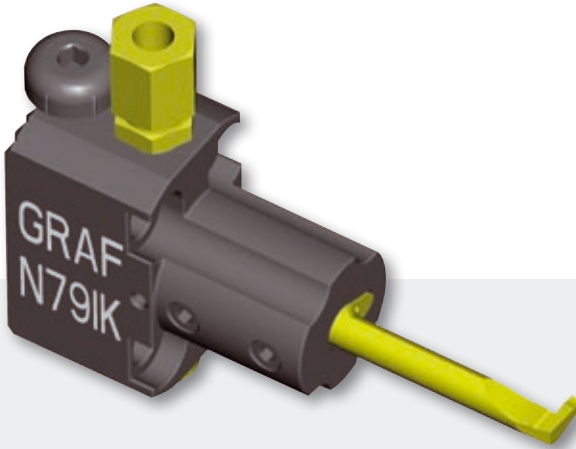

N791K

Anwendungsbereich **Innenbearbeitung**
Range of application **internal processing**

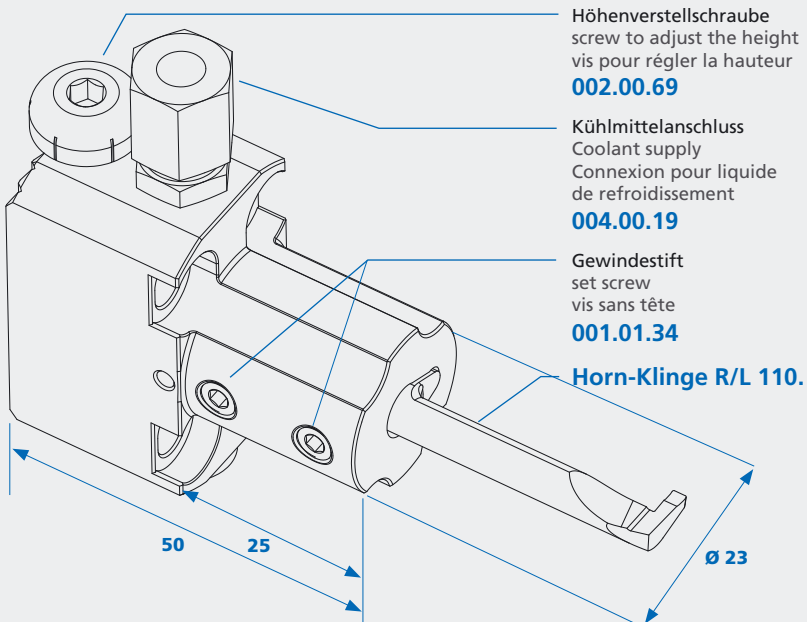

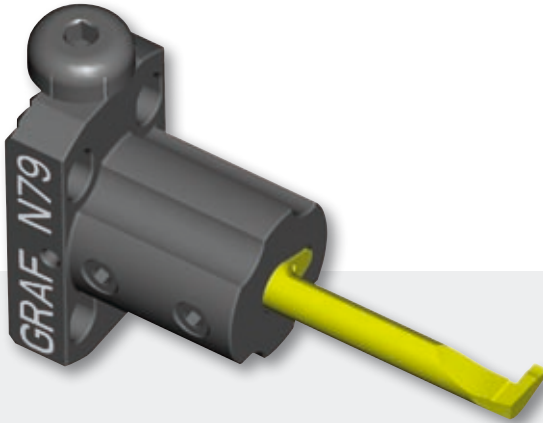

N79

Anwendungsbereich **Innenbearbeitung**
Range of application **internal processing**

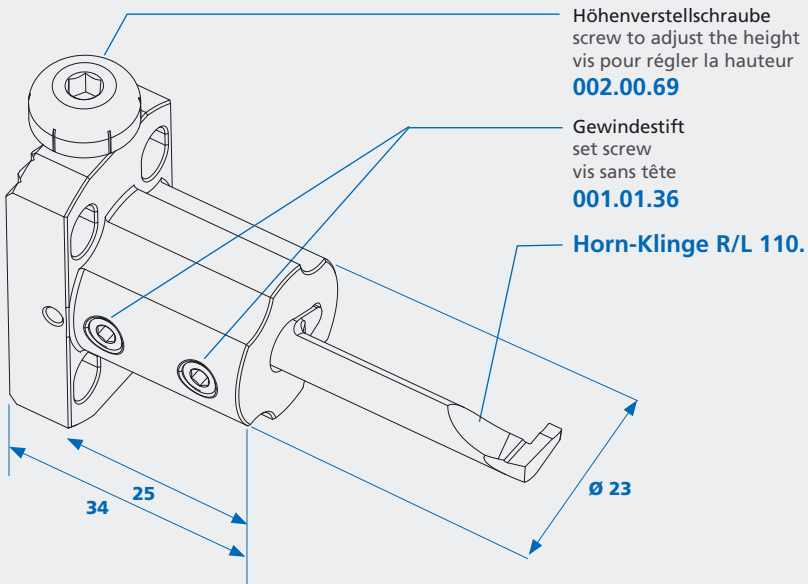

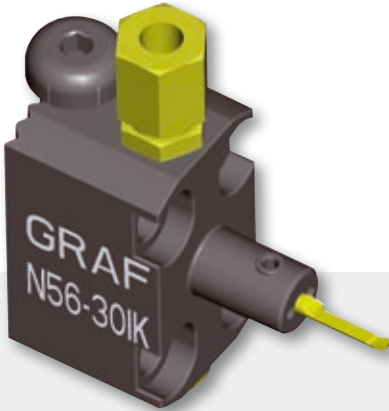

N56-30IK

Anwendungsbereich **Innenbearbeitung**
Range of application **internal processing**

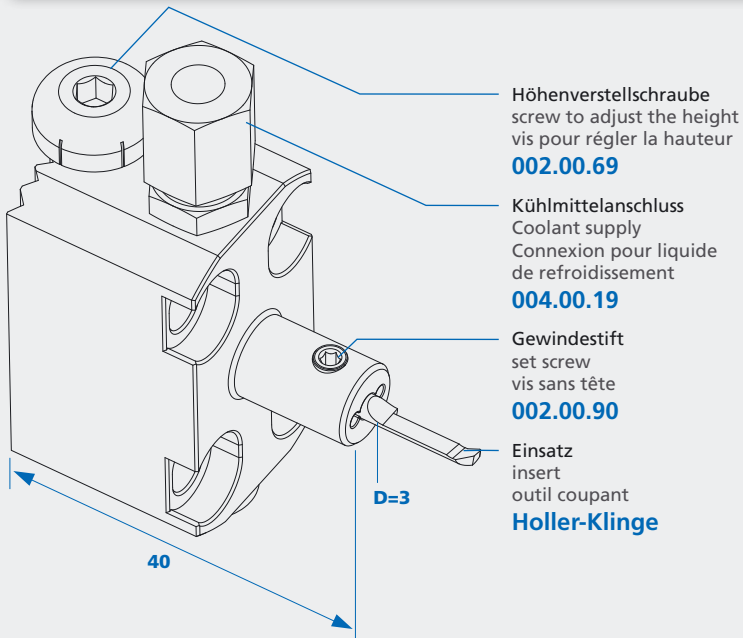

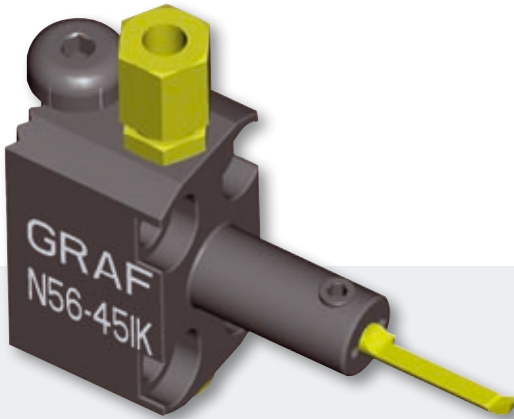

N56-45IK

Anwendungsbereich **Innenbearbeitung**
Range of application **internal processing**

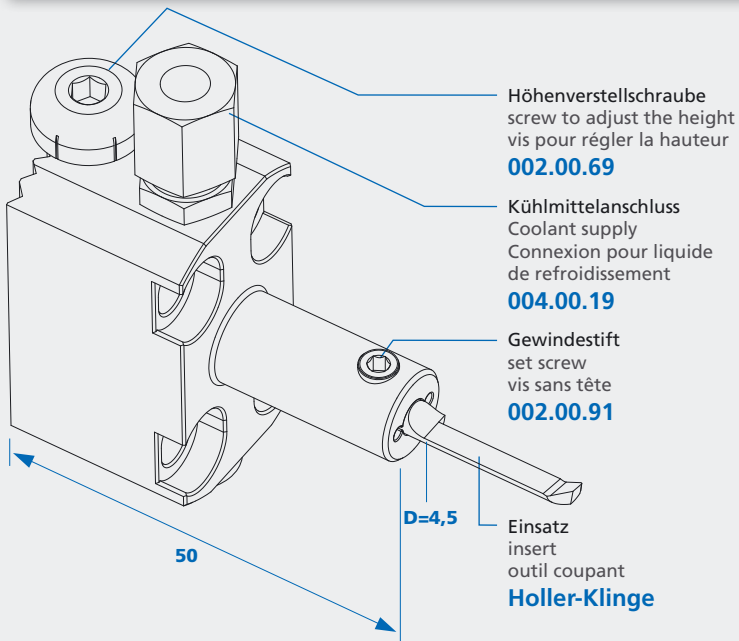

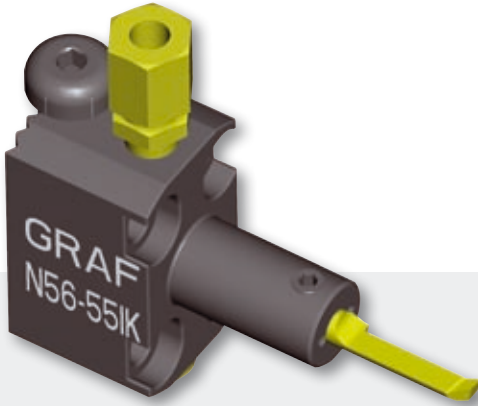

N56-55IK

Anwendungsbereich **Innenbearbeitung**
Range of application **internal processing**

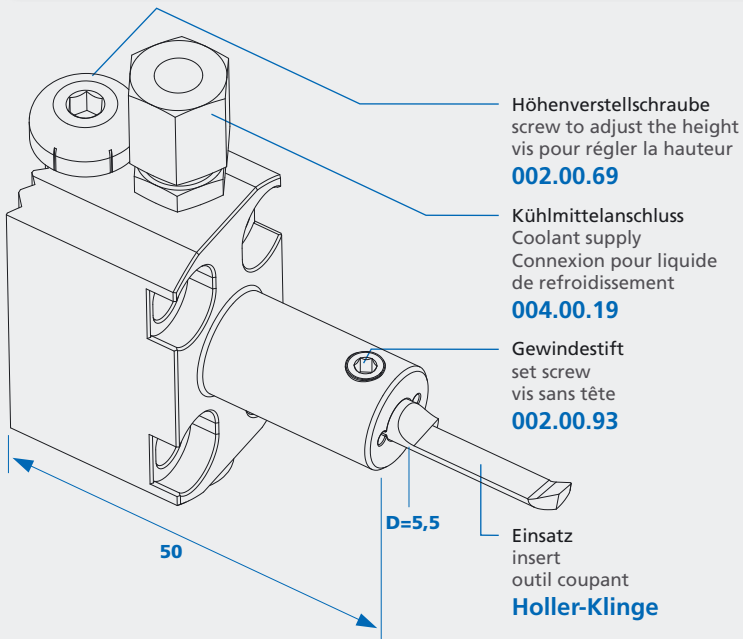

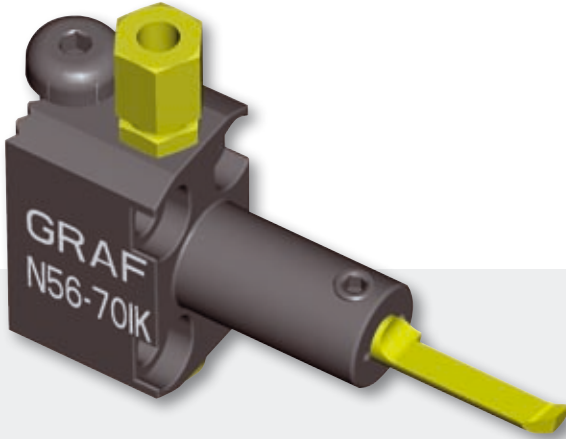

N56-70IK

Anwendungsbereich **Innenbearbeitung**
Range of application **internal processing**

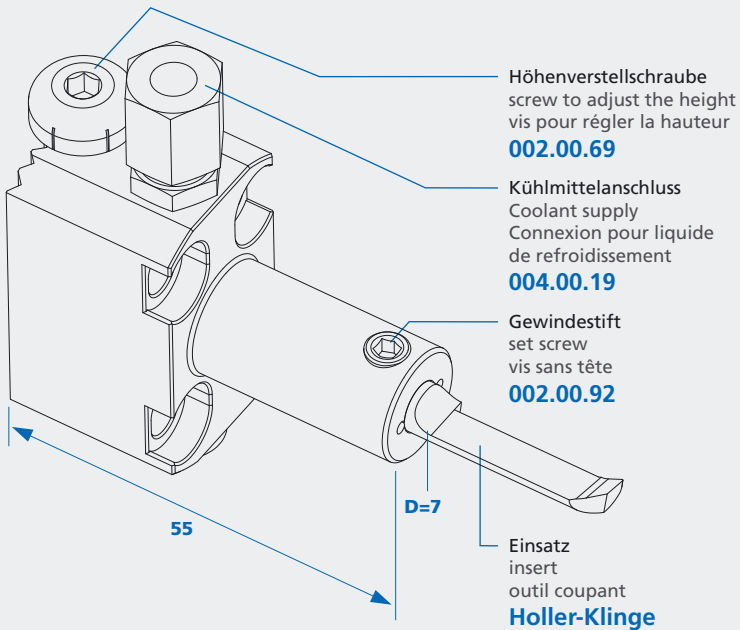

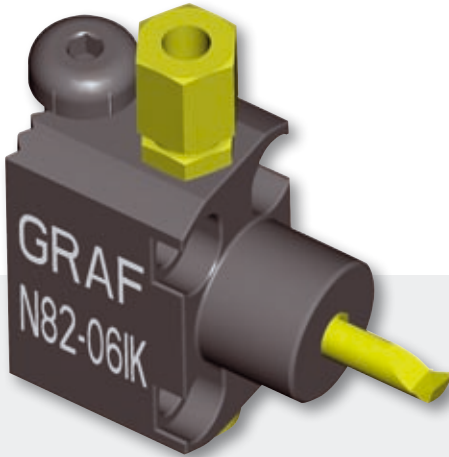

N82-061K

Anwendungsbereich **Innenbearbeitung**
Range of application **internal processing**

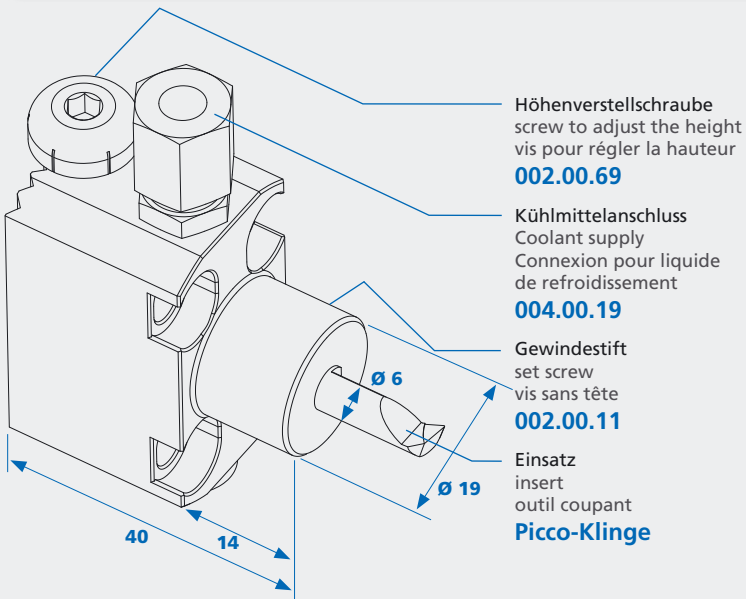



N83-05IK

Anwendungsbereich **Innenbearbeitung**
Range of application **internal processing**

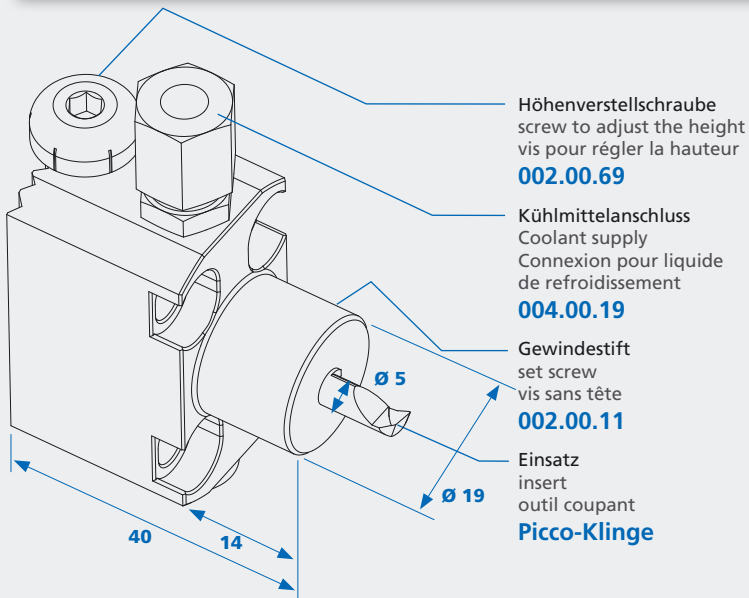

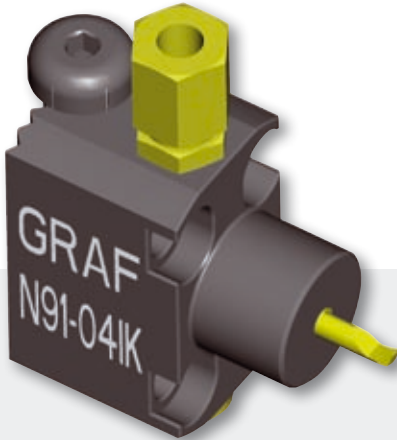

N91-04IK

Anwendungsbereich **Innenbearbeitung**
Range of application **internal processing**

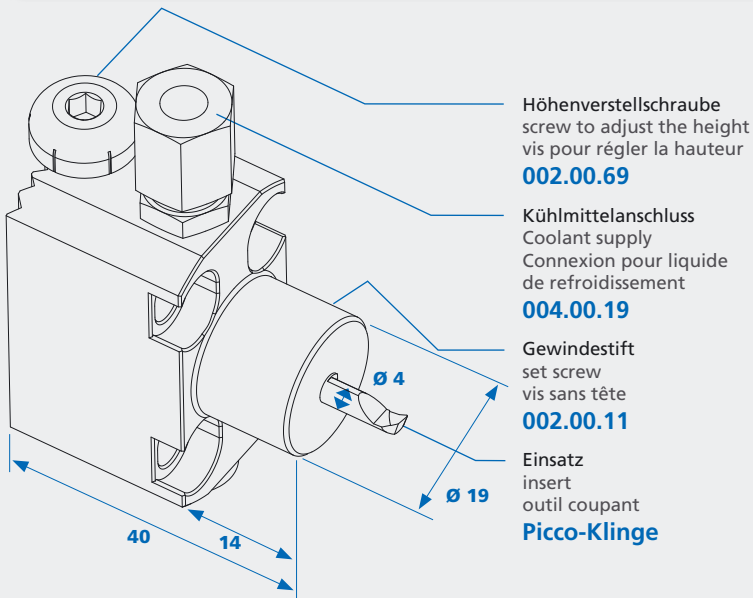

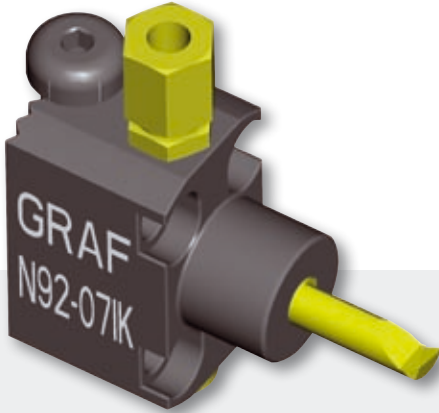

N92-07IK

Anwendungsbereich **Innenbearbeitung**
Range of application **internal processing**

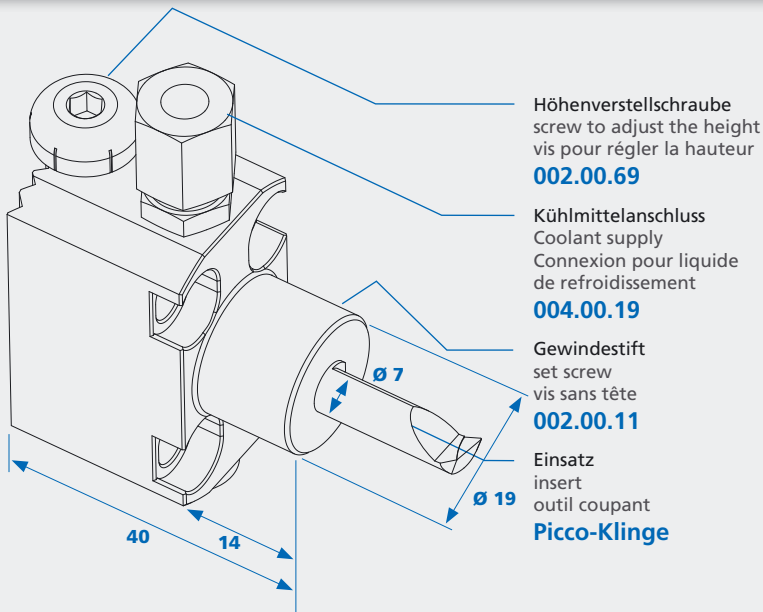

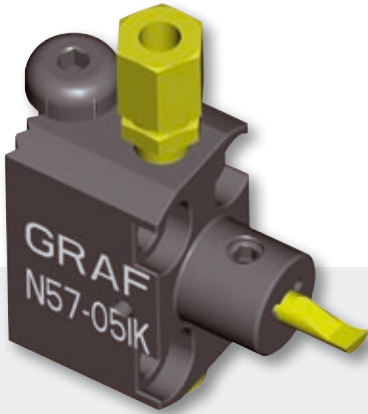

N57-051K

Anwendungsbereich **Innenbearbeitung**
Range of application **internal processing**

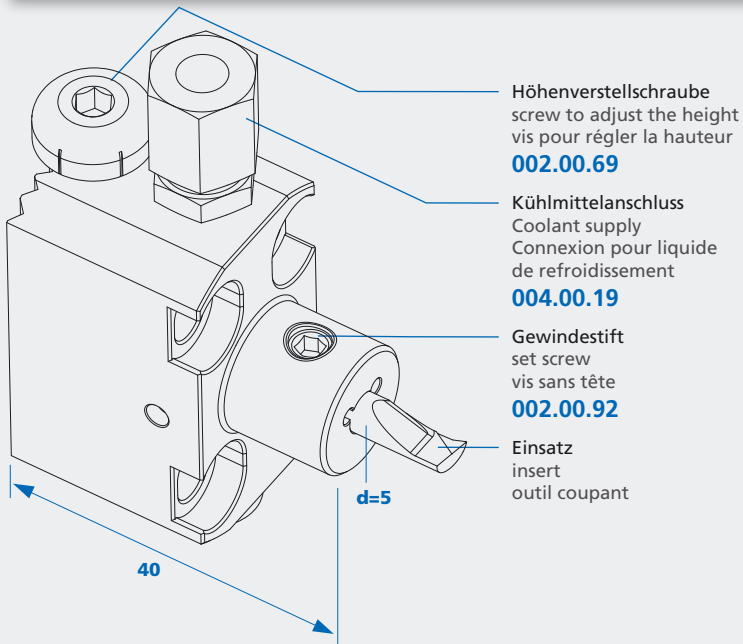



N58-04IK

Anwendungsbereich **Innenbearbeitung**
Range of application **internal processing**

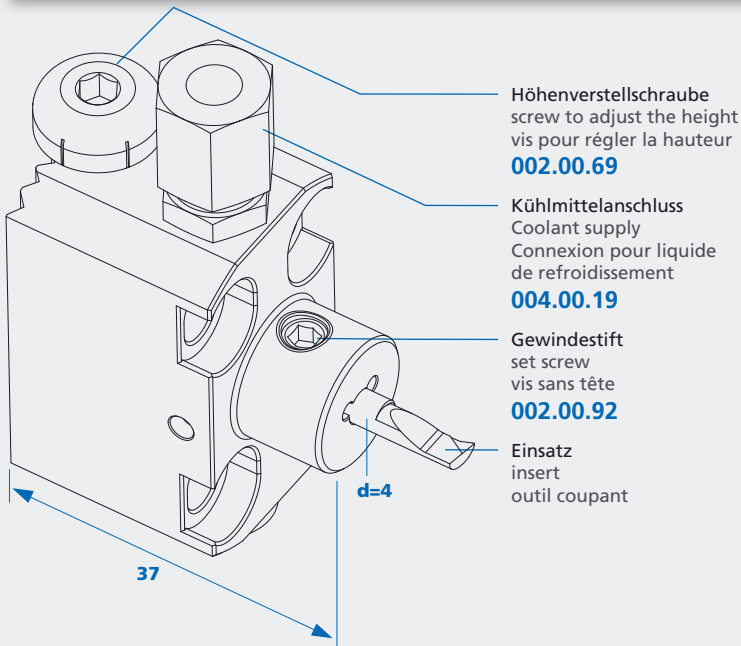

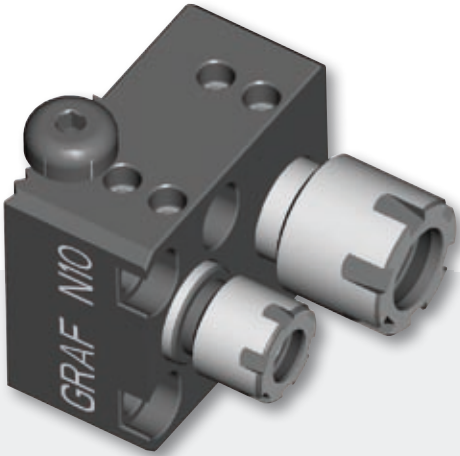

N10

Anwendungsbereich **Rückseitenbearbeitung**
Application **back working**

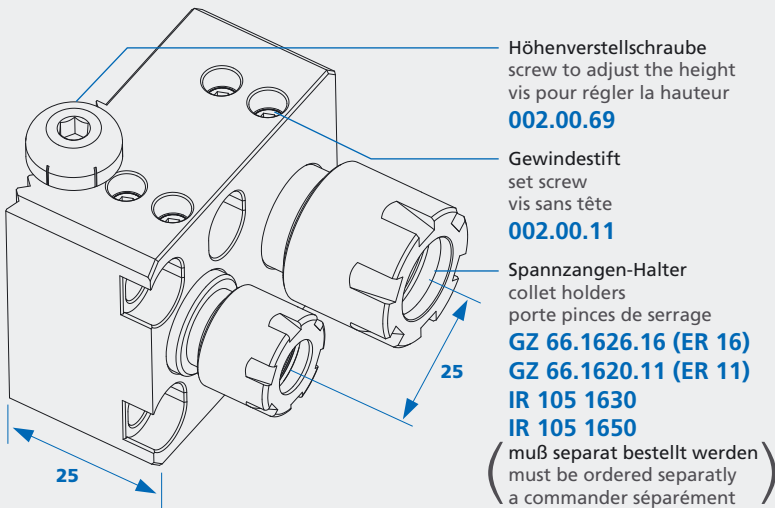

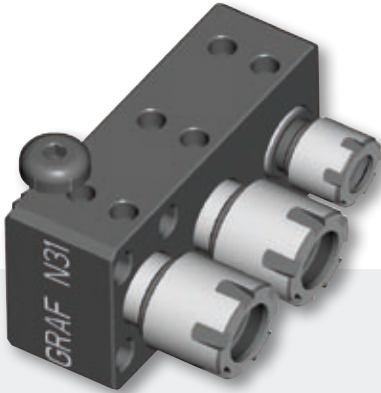

N31

Anwendungsbereich **Rückseitenbearbeitung**
Application **back working**

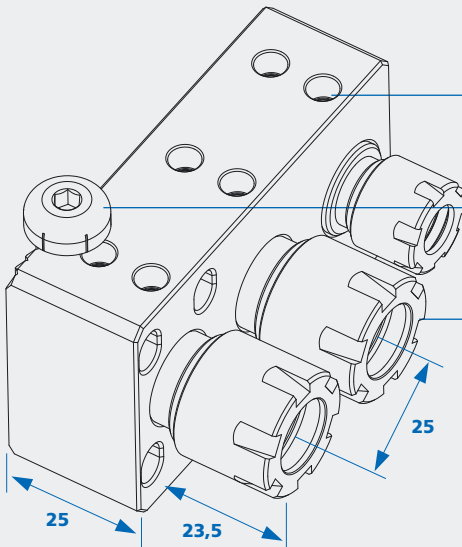

Gewindestift
set screw
vis sans tête
001.01.24

Höhenverstellungsschraube
screw to adjust the height
vis pour régler la hauteur
002.00.69

Spannzangen-Halter
collet holders
porte pinces de serrage
GZ 66.1620.11 (ER 11)
GZ 66.1626.16 (ER 16)
oder IR 105.1630
IR 105 1630
IR 105 1650

(muß separat bestellt werden)
(must be ordered separately)
(a commander séparément)

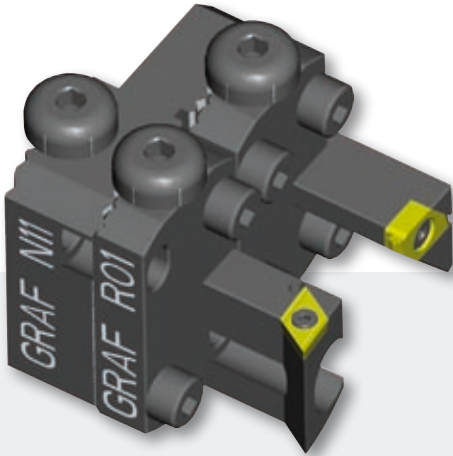

N11

Anwendungsbereich **Rückseitenbearbeitung**
Application **back working**

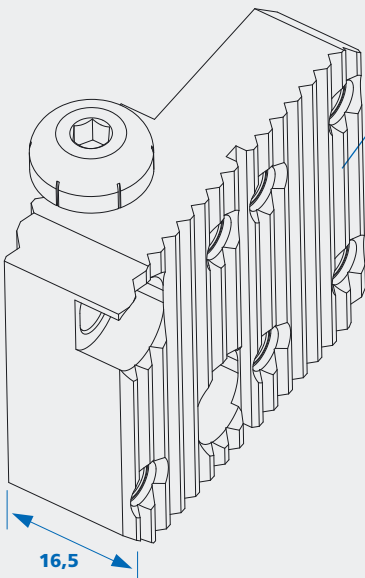

2 Einsätze wahlweise
2 alternatively inserts
2 inserts au choix

16,5

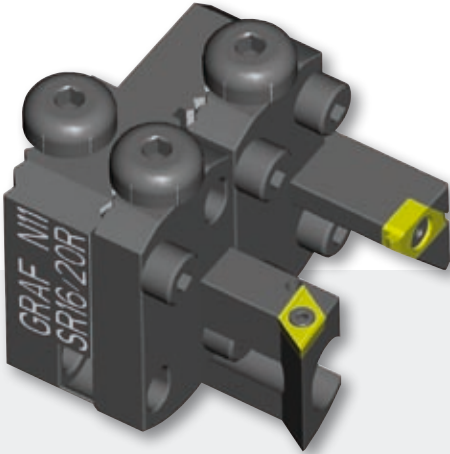

N11SR16/20R

Anwendungsbereich **Rückseitenbearbeitung**
Application **back working**

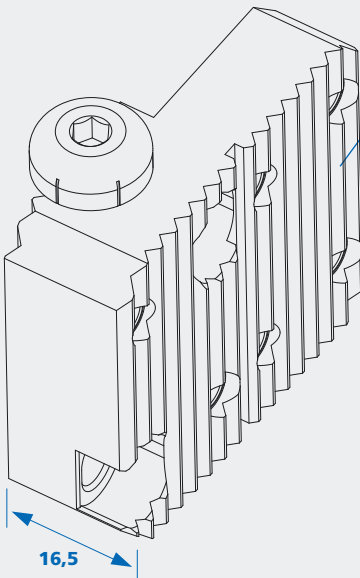

2 Einsätze wahlweise
2 alternatively inserts
2 inserts au choix

Für Grundhalter	G 022 025 SR16/20R
For basic holder	G 022 030 SR32
	G 025 060
Pour porte-outil de base	G 028 006
	G 028 040
	G 028 080
	G 032 25
	G 033 40

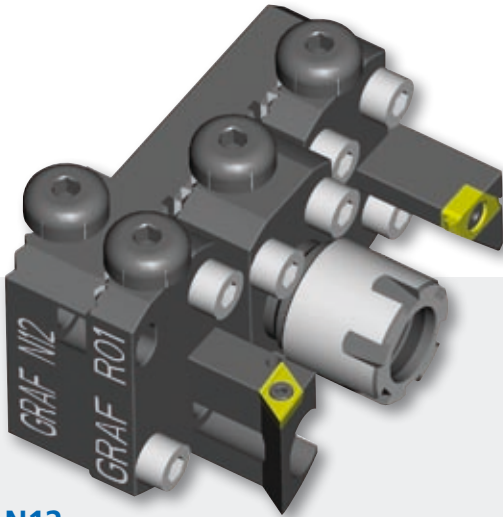

N12

Anwendungsbereich **Rückseitenbearbeitung**
Application **back working**

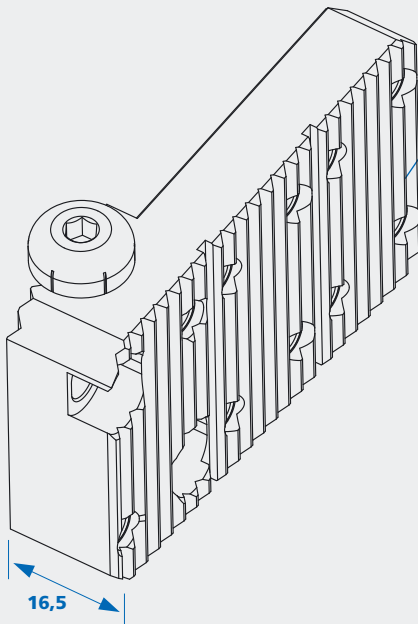

3 Einsätze wahlweise
3 alternatively inserts
3 inserts au choix

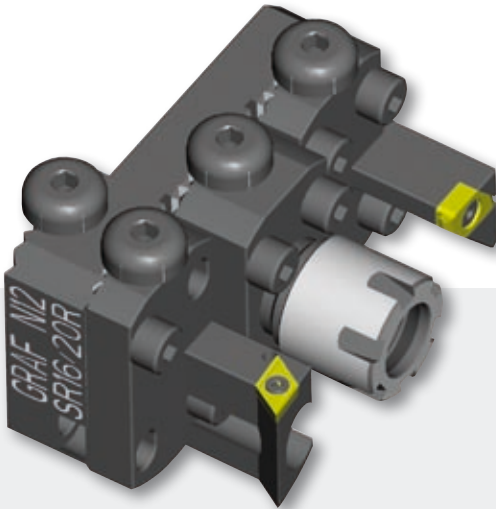

N12 SR16/20 R

Anwendungsbereich **Rückseitenbearbeitung**
Application **back working**

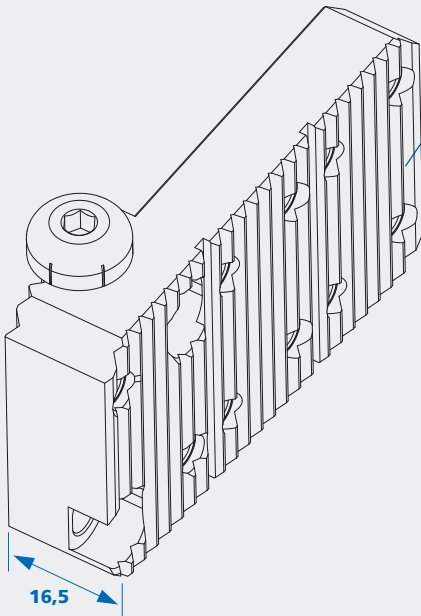

3 Einsätze wahlweise
3 alternatively inserts
3 inserts au choix

Für Grundhalter

G 022 025 SR16/20R

For basic holder

G 022 030 SR32

G 025 060

Pour porte-outil
de base

G 028 006

G 028 040

G 028 080

G 032 25

G 033 40

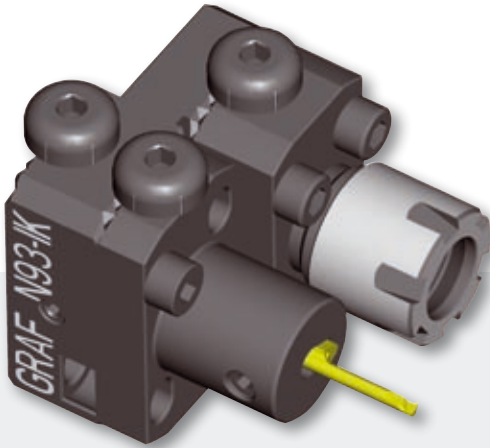

N93IK

Anwendungsbereich **Rückseitenbearbeitung**
Application **back working**

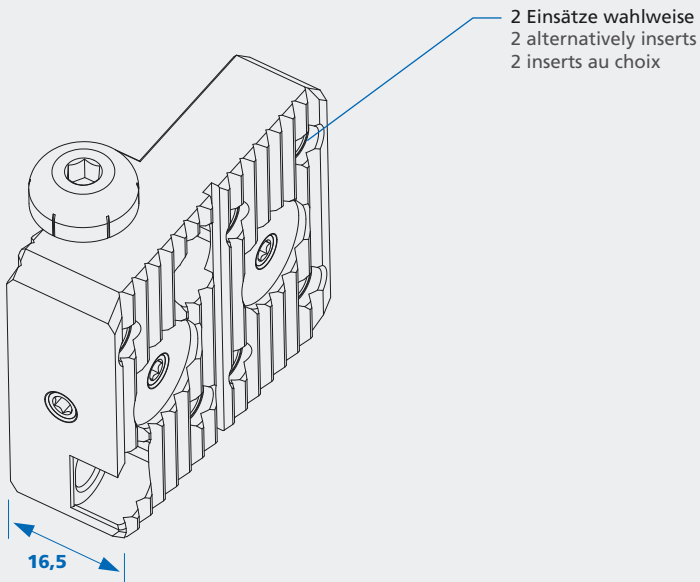



L

linksschneidend
cutting left
couper gauche

L59



R

rechtsschneidend
cutting right
couper droit

R59

Anwendungsbereich **Kopierdrehen**
Application **copy turning**

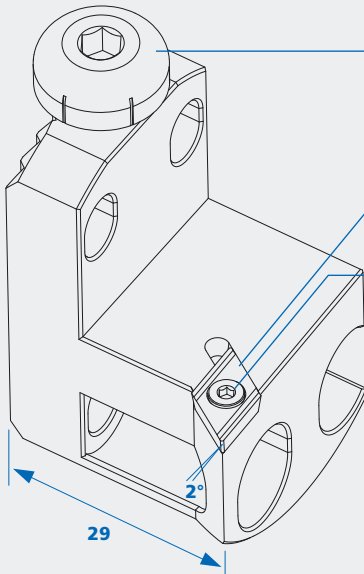

Höhenverstellungsschraube
screw to adjust the height
vis pour régler la hauteur
002.00.69

Wendepatte
indexable insert
plaquette réversible
DC 07.02..

Senkschraube
counter sunk-head screw
vis à tête noyée
001.01.01

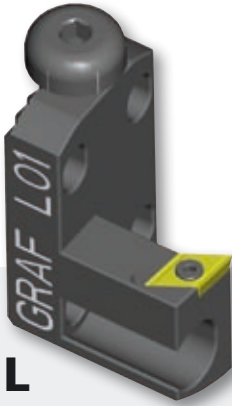

L

linksschneidend
cutting left
couper gauche

L01

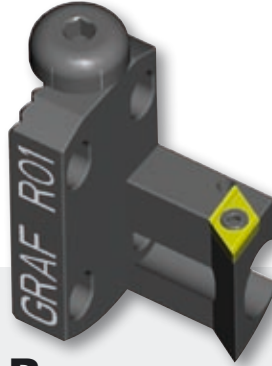

R

rechtsschneidend
cutting right
couper droit

R01

Anwendungsbereich **Kopierdrehen**
Application **copy turning**

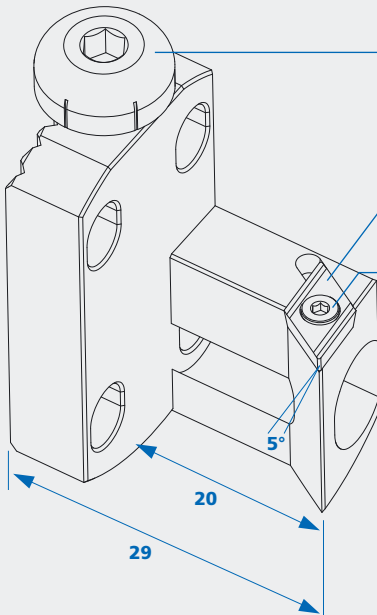

Höhenverstellungsschraube
screw to adjust the height
vis pour régler la hauteur

002.00.69

Wendeplatte
indexable insert
plaquette réversible

DC.. 07 02 ..

Senkschraube
counter sunk-head screw
vis à tête noyée

001.01.01



L
linksschneidend
cutting left
couper gauche

L75

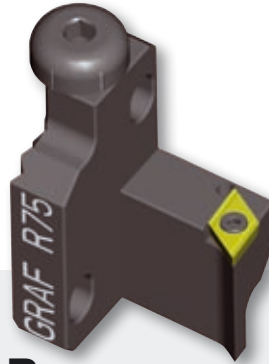

R
rechtsschneidend
cutting right
couper droit

R75

Anwendungsbereich **Kopierdrehen**
Application **copy turning**

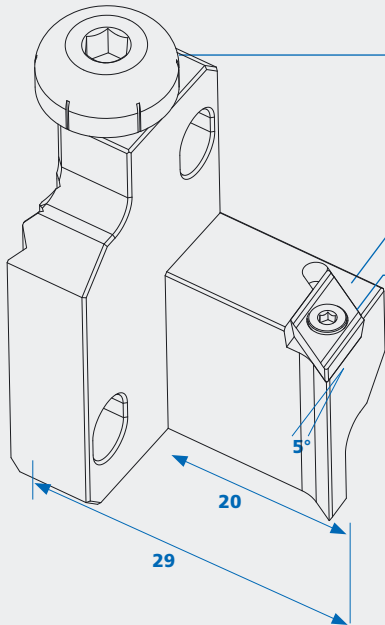

Höhenverstellungsschraube
screw to adjust the height
vis pour régler la hauteur
002.00.69

Wendeplatte
indexable insert
plaquette réversible
DC.. 07 02 ..

Senkschraube
counter sunk-head screw
vis à tête noyée
001.01.01

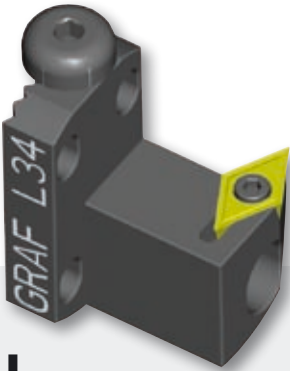

L

linksschneidend
cutting left
couper gauche

L34



R

rechtsschneidend
cutting right
couper droit

R34

Anwendungsbereich **Kopierdrehen**
Application **copy turning**

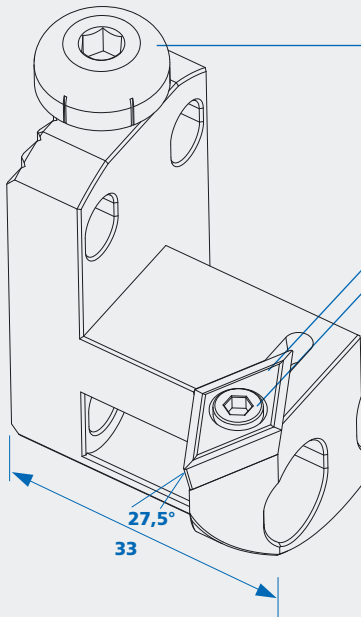

Höhenverstellungsschraube
screw to adjust the height
vis pour régler la hauteur

002.00.69

Wendepatte
indexable insert
plaquette réversible

DC.. 11 T3 ..

Senkschraube
counter sunk-head screw
vis à tête noyée

001.01.15

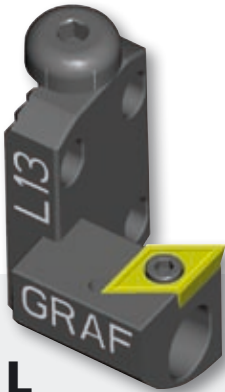

L

linksschneidend
cutting left
couper gauche

L13

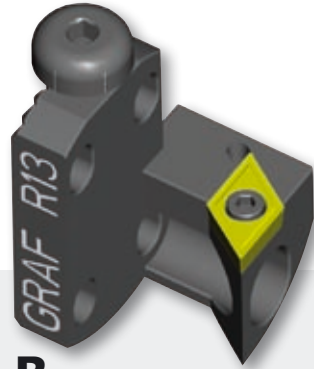

R

rechtsschneidend
cutting right
couper droit

R13

Anwendungsbereich **Kopierdrehen**
Application **copy turning**

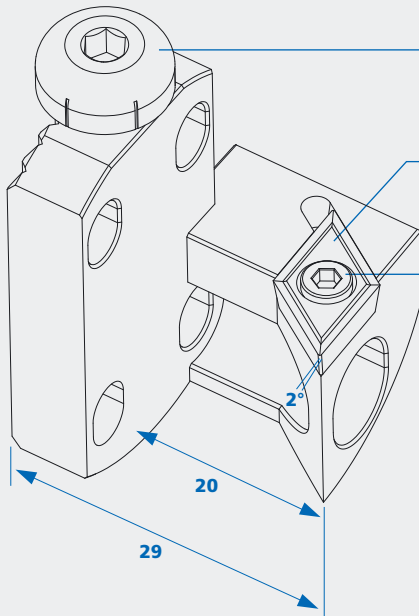

Höhenverstellungsschraube
screw to adjust the height
vis pour régler la hauteur
002.00.69

Wendeplatte
indexable insert
plaquette réversible
DC.. 11 T3 ..

Senkschraube
counter sunk-head screw
vis à tête noyée
001.01.15



L

linksschneidend
cutting left
couper gauche

L14K

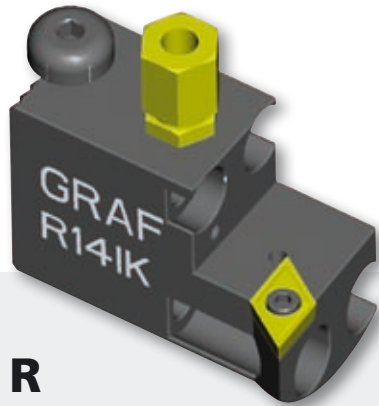

R

rechtsschneidend
cutting right
couper droit

R14K

Anwendungsbereich **Kopierdrehen**
Application **copy turning**

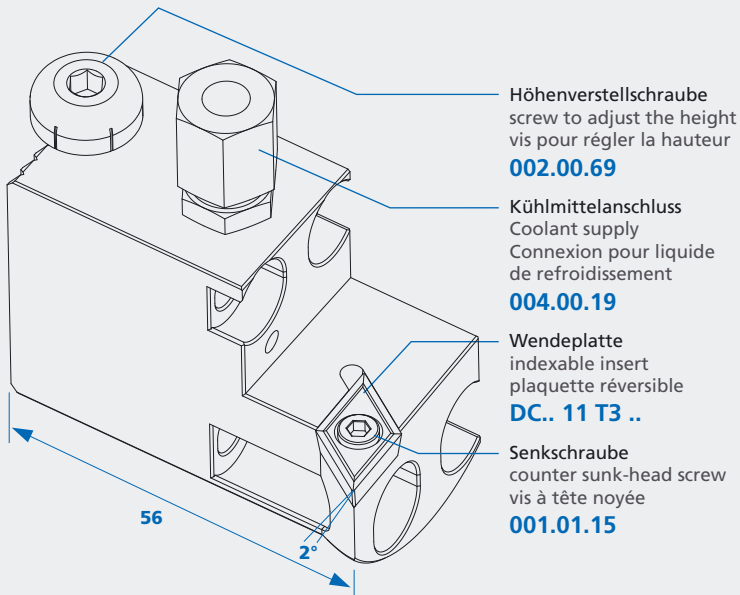



L

linksschneidend
cutting left
couper gauche

L721K



R

rechtsschneidend
cutting right
couper droit

R721K

Anwendungsbereich **Kopierdrehen**
Application **copy turning**

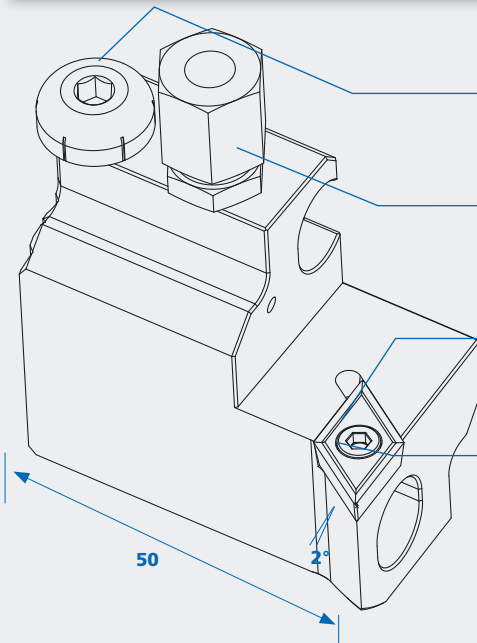

Höhenverstellungsschraube
screw to adjust the height
vis pour régler la hauteur
002.00.69

Kühlmittelanschluss
Coolant supply
Connexion pour liquide
de refroidissement
004.00.19

Wendeplatte
indexable insert
plaquette réversible
DC.. 11 T3 ..

Senkschraube
counter sunk-head screw
vis à tête noyée
001.01.15

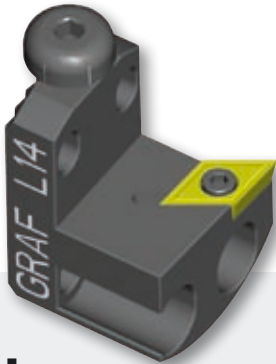

L

linksschneidend
cutting left
couper gauche

L14

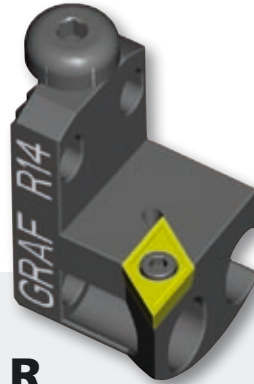

R

rechtsschneidend
cutting right
couper droit

R14

Anwendungsbereich **Kopierdrehen**
Application **copy turning**

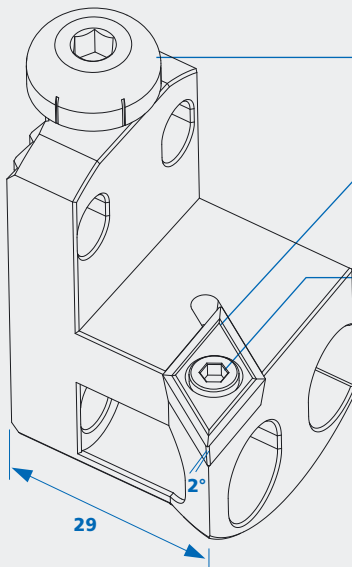

Höhenverstellungsschraube
screw to adjust the height
vis pour régler la hauteur
002.00.69

Wendplatte
indexable insert
plaquette réversible
DC.. 11 T3 ..

Senkschraube
counter sunk-head screw
vis à tête noyée
001.01.15



L

linksschneidend
cutting left
couper gauche

L72

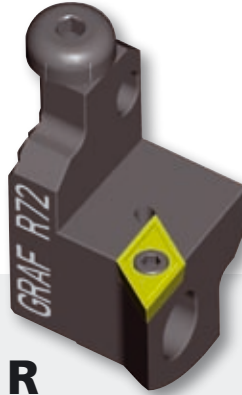

R

rechtsschneidend
cutting right
couper droit

R72

Anwendungsbereich **Kopierdrehen**
Application **copy turning**

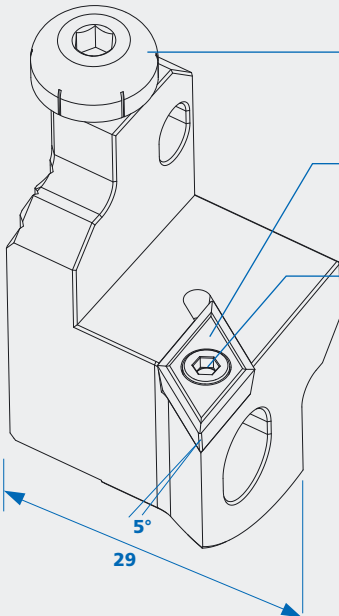

Höhenverstelle
screw to adjust the height
vis pour régler la hauteur
002.00.69

Wendeplatte
indexable insert
plaquette réversible
DC.. 11 T3 ..

Senkschraube
counter sunk-head screw
vis à tête noyée
001.01.15



L

linksschneidend
cutting left
couper gauche

L71

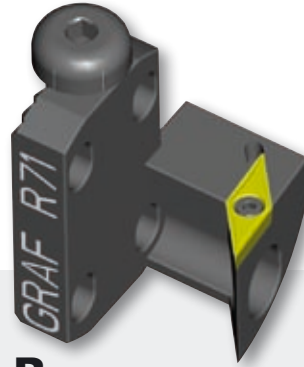

R

rechtsschneidend
cutting right
couper droit

R71

Anwendungsbereich **Kopierdrehen**
Application **copy turning**

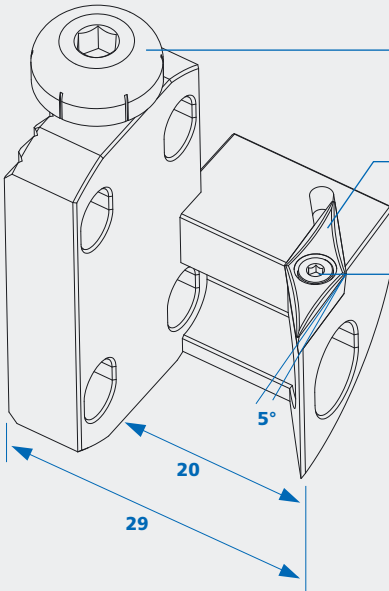

Höhenverstellungsschraube
screw to adjust the height
vis pour régler la hauteur
002.00.69

Wendeplatte
indexable insert
plaquette réversible
VB 11.03..

Senkschraube
counter sunk-head screw
vis à tête noyée
001.01.08

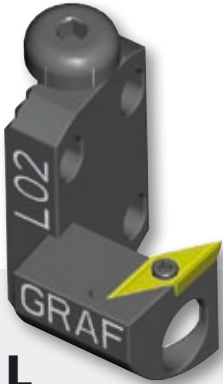

L

linksschneidend
cutting left
couper gauche

L02

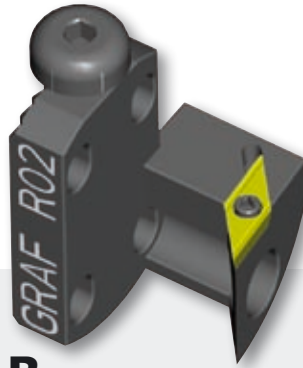

R

rechtsschneidend
cutting right
couper droit

R02

Anwendungsbereich **Kopierdrehen**
Application **copy turning**

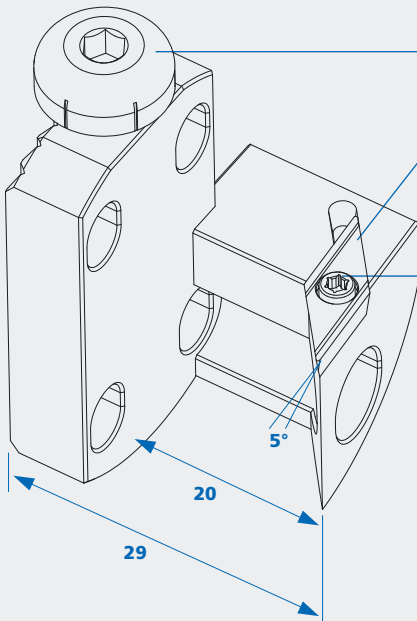

Höhenverstelle schraube
screw to adjust the height
vis pour régler la hauteur
002.00.69

Wendeplatte
indexable insert
plaquette réversible
VC.. 11 03 ..

Senkschraube
counter sunk-head screw
vis à tête noyée
001.01.08

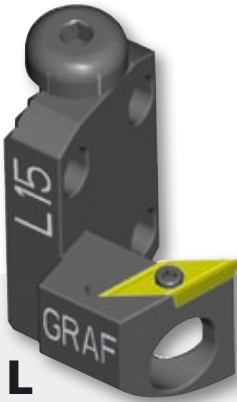

L

linksschneidend
cutting left
couper gauche

L15

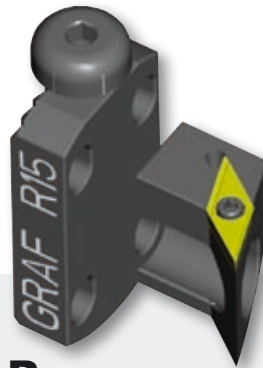

R

linksschneidend
cutting left
couper gauche

R15

Anwendungsbereich **Kopierdrehen**
Application **copy turning**

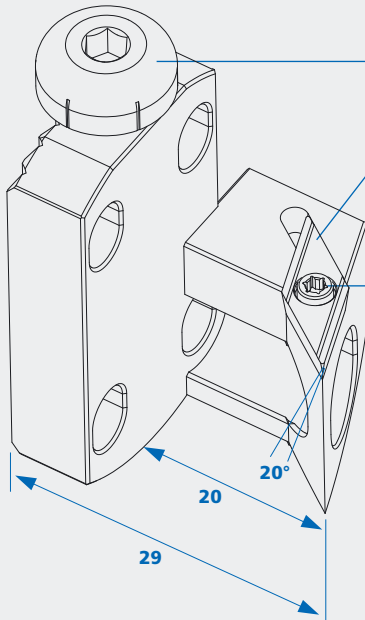

Höhenverstellungsschraube
screw to adjust the height
vis pour régler la hauteur

002.00.69

Wendepatte
indexable insert
plaquette réversible

VC.. 11 03 ..

Senkschraube
counter sunk-head screw
vis à tête noyée

001.01.08



L

linksschneidend
cutting left
couper gauche

L96

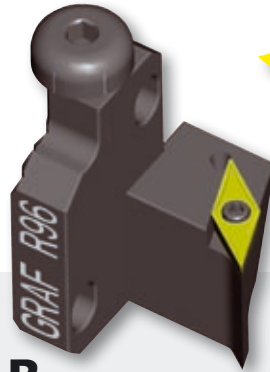

R

rechtsschneidend
cutting right
couper droit

R96

Anwendungsbereich **Kopierdrehen**
Application **copy turning**

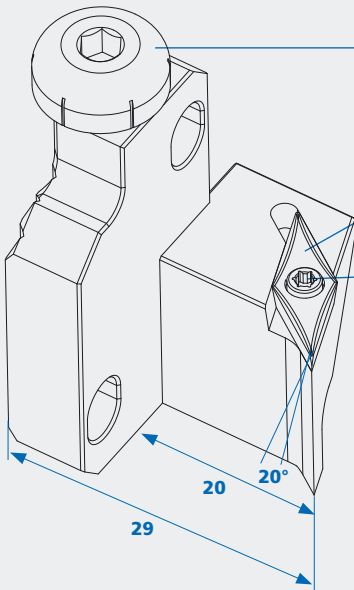

Höhenverstellungsschraube
screw to adjust the height
vis pour régler la hauteur
002.00.69

Wendeplatte
indexable insert
plaquette réversible
VC 11.03..

Senkschraube
counter sunk-head screw
vis à tête noyée
001.01.08

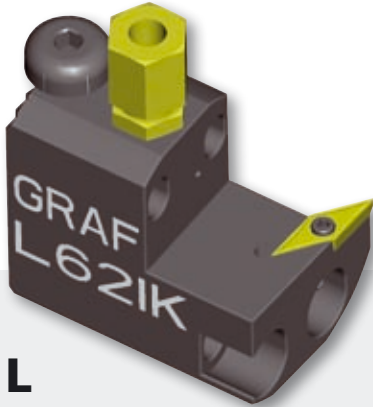

L

linksschneidend
cutting left
couper gauche

L62IK



R

rechtsschneidend
cutting right
couper droit

R62IK

Anwendungsbereich **Kopierdrehen**
Application **copy turning**

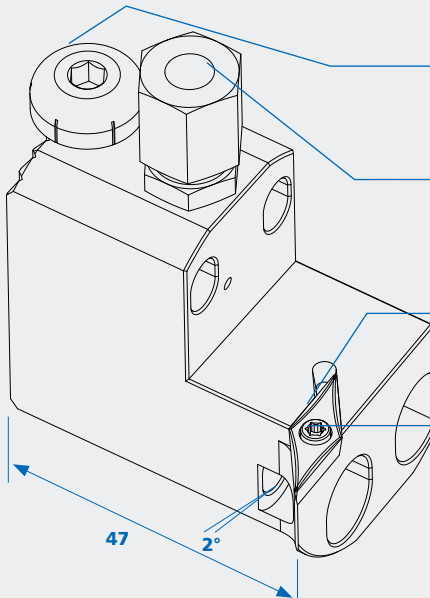

Höhenverstellungsschraube
screw to adjust the height
vis pour régler la hauteur
002.00.69

Kühlmittelanschluss
Coolant supply
Connexion pour liquide de refroidissement
004.00.19

Wendeplatte
indexable insert
plaquette réversible
VC 11.03..

Senkschraube
counter sunk-head screw
vis à tête noyée
001.01.08

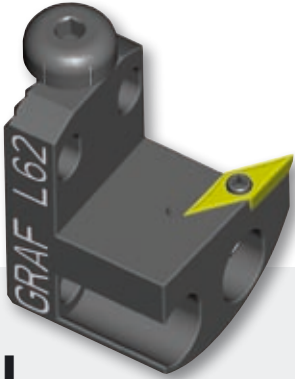

L

linksschneidend
cutting left
couper gauche

L62

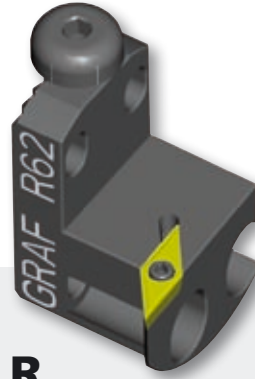

R

rechtsschneidend
cutting right
couper droit

R62

Anwendungsbereich **Kopierdrehen**
Application **copy turning**

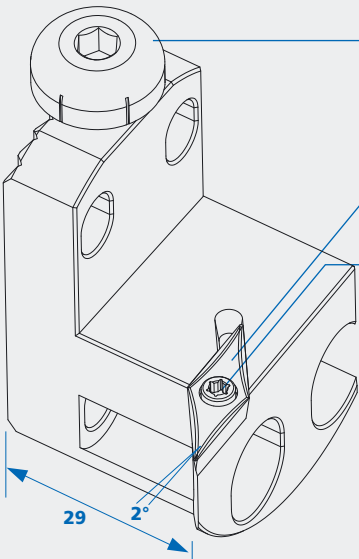

Höhenverstellungsschraube
screw to adjust the height
vis pour régler la hauteur

002.00.69

Wendepalette
indexable insert
plaquette réversible

VC 11.03..

Senkschraube
counter sunk-head screw
vis à tête noyée

001.01.08



L

linksschneidend
cutting left
couper gauche

L60

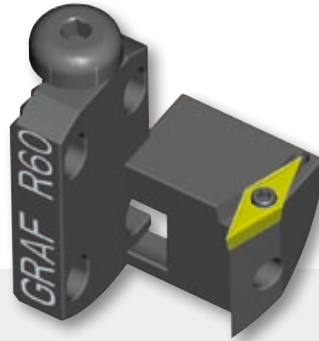

R

rechtsschneidend
cutting right
couper droit

R60

Anwendungsbereich **Kopierdrehen**
Application **copy turning**

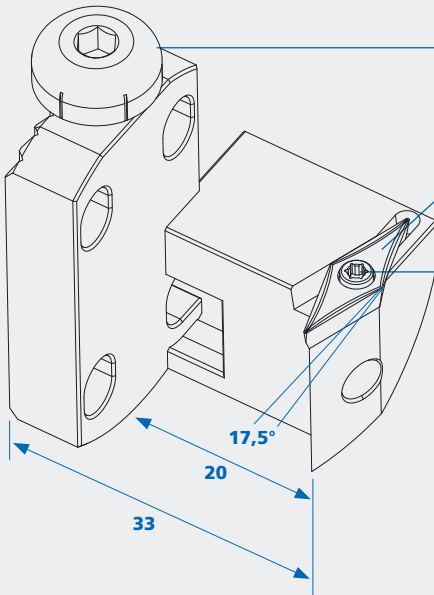

Höhenverstellungsschraube
screw to adjust the height
vis pour régler la hauteur
002.00.69

Wendeplatte
indexable insert
plaquette réversible
VC 11.03..

Senkschraube
counter sunk-head screw
vis à tête noyée
001.01.08

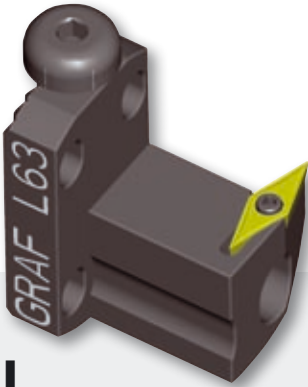

L

linksschneidend
cutting left
couper gauche

L63



R

rechtsschneidend
cutting right
couper droit

R63

Anwendungsbereich **Kopierdrehen**
Application **copy turning**

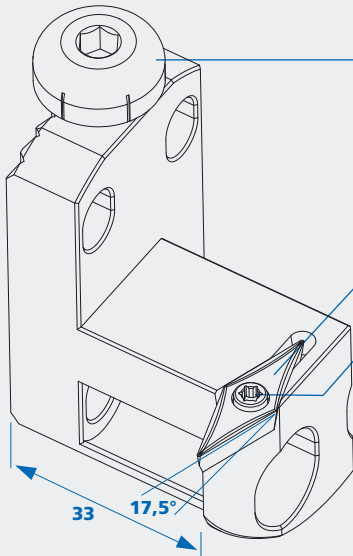

Höhenverstellungsschraube
screw to adjust the height
vis pour régler la hauteur
002.00.69

Wendeplatte
indexable insert
plaquette réversible
VC 11.03..

Senkschraube
counter sunk-head screw
vis à tête noyée
001.01.08



L

linksschneidend
cutting left
couper gauche

L17IK

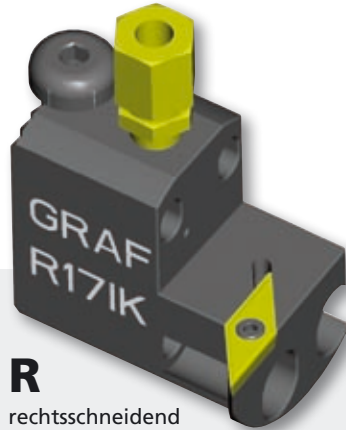

R

rechtsschneidend
cutting right
couper droit

R17IK

Anwendungsbereich **Kopierdrehen**
Application **copy turning**

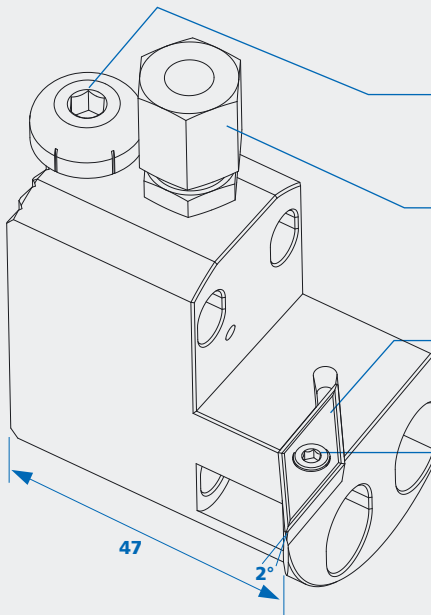

Höhenverstellungsschraube
screw to adjust the height
vis pour régler la hauteur
002.00.69

Kühlmittelanschluss
Coolant supply
Connexion pour liquide
de refroidissement
004.00.19

Wendepatte
indexable insert
plaquette réversible
VC.. 13 03 ..

Senkschraube
counter sunk-head screw
vis à tête noyée
001.01.07

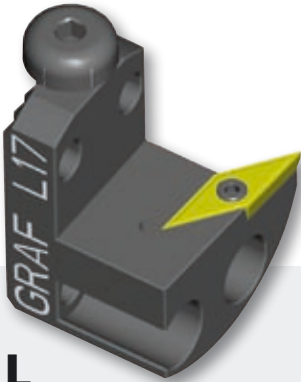

L

linksschneidend
cutting left
couper gauche

L17

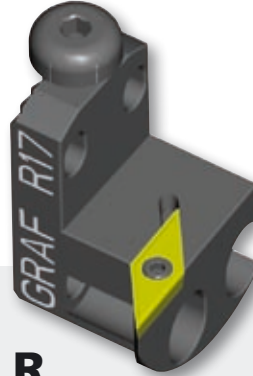

R

rechtsschneidend
cutting right
couper droit

R17

Anwendungsbereich **Kopierdrehen**
Application **copy turning**

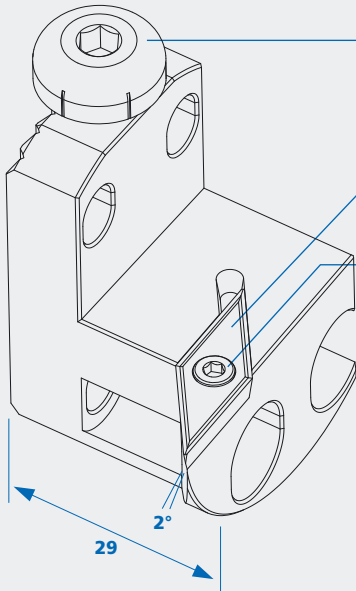

Höhenverstellungsschraube
screw to adjust the height
vis pour régler la hauteur
002.00.69

Wendeplatte
indexable insert
plaquette réversible
VC.. 13 03 ..

Senkschraube
counter sunk-head screw
vis à tête noyée
001.01.07

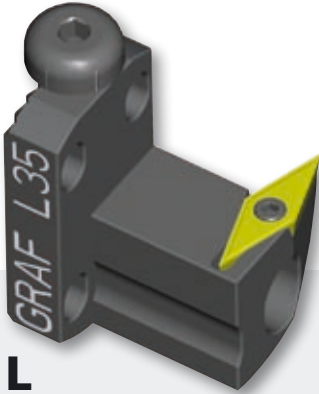

L

linksschneidend
cutting left
couper gauche

L35



R

rechtsschneidend
cutting right
couper droit

R35

Anwendungsbereich **Kopierdrehen**
Application **copy turning**

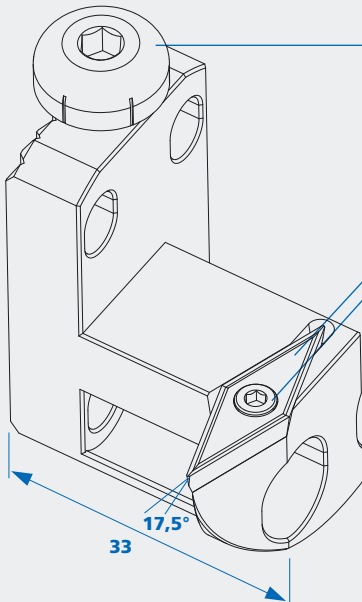

Höhenverstellungsschraube
screw to adjust the height
vis pour régler la hauteur
002.00.69

Wendeplatte
indexable insert
plaquette réversible
VC.. 13 03 ..

Senkschraube
counter sunk-head screw
vis à tête noyée
001.01.07

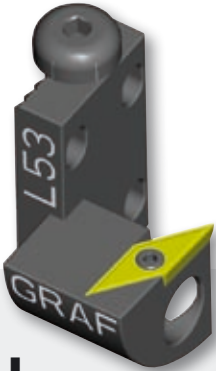

L

linksschneidend
cutting left
couper gauche

L53

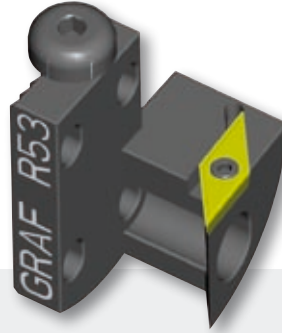

R

rechtsschneidend
cutting right
couper droit

R53

Anwendungsbereich **Kopierdrehen**
Application **copy turning**

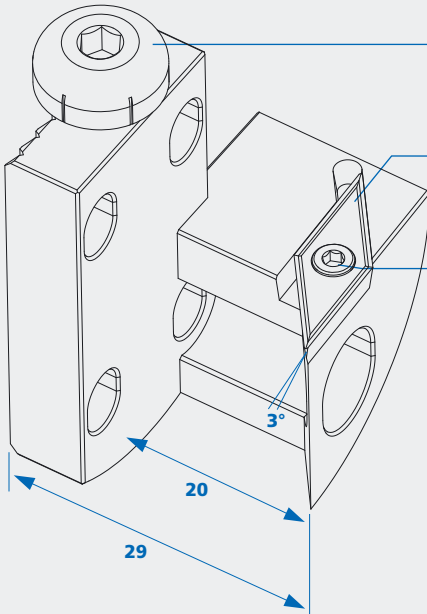

Höhenverstellungsschraube
screw to adjust the height
vis pour régler la hauteur
002.00.69

Wendeplatte
indexable insert
plaquette réversible
VC..13 03...

Senkschraube
counter sunk-head screw
vis à tête noyée
001.01.07

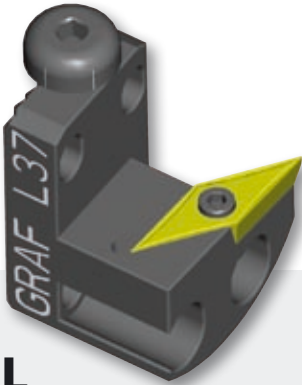

L

linksschneidend
cutting left
couper gauche

L37

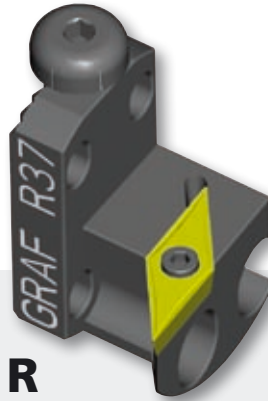

R

rechtsschneidend
cutting right
couper droit

R37

Anwendungsbereich **Kopierdrehen**
Application **copy turning**

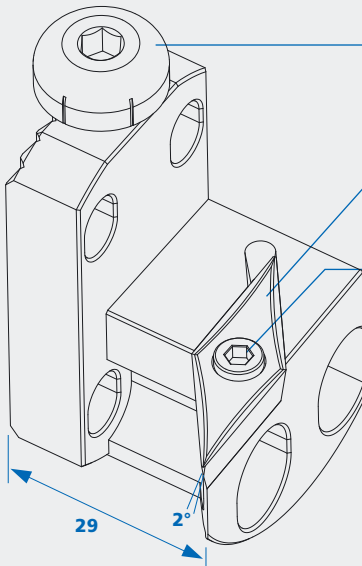

Höhenverstellungsschraube
screw to adjust the height
vis pour régler la hauteur
002.00.69

Wendeplatte
indexable insert
plaquette réversible
VC.. 16 04 ..

Senkschraube
counter sunk-head screw
vis à tête noyée
001.01.15

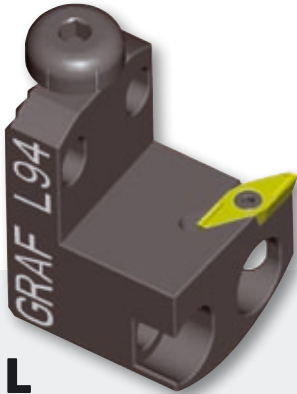

L

linksschneidend
cutting left
couper gauche

L94



R

rechtsschneidend
cutting right
couper droit

R94



Anwendungsbereich **Langdrehen**
Application **turning**

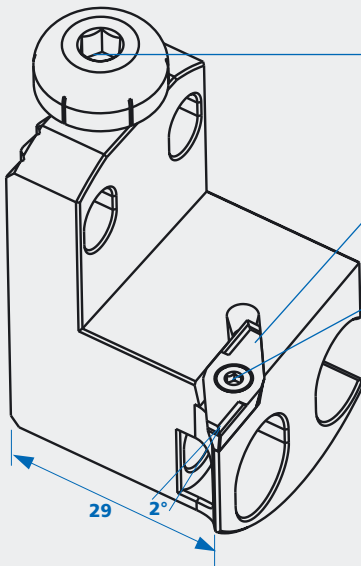

Höhenverstellungsschraube
screw to adjust the height
vis pour régler la hauteur
002.00.69

Wendeplatte
indexable insert
plaquette réversible
VP. 10 03 ..

Senkschraube
counter sunk-head screw
vis à tête noyée
001.01.33



L

linksschneidend
cutting left
couper gauche

L70IK

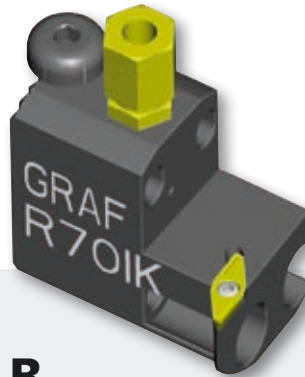

R

rechtsschneidend
cutting right
couper droit

R70IK

Anwendungsbereich **Langdrehen**
Application **turning**

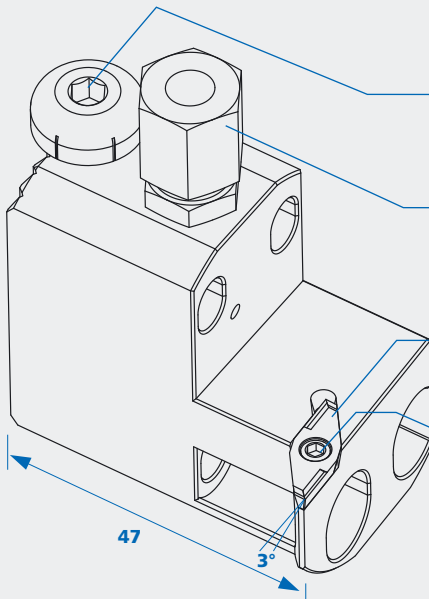

Höhenverstellungsschraube
screw to adjust the height
vis pour régler la hauteur
002.00.69

Kühlmittelanschluss
Coolant supply
Connexion pour liquide
de refroidissement
004.00.19

Wendepatte
indexable insert
plaquette réversible
Applitec Typ 300

Senkschraube
counter sunk-head screw
vis à tête noyée
001.01.33

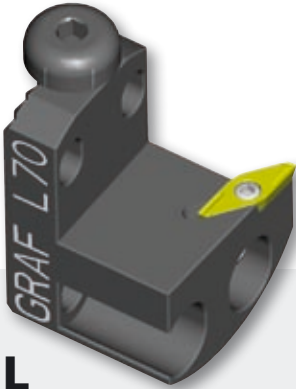

L
linksschneidend
cutting left
couper gauche

L70



R
rechtsschneidend
cutting right
couper droit

R70

Anwendungsbereich **Langdrehen**
Application **turning**

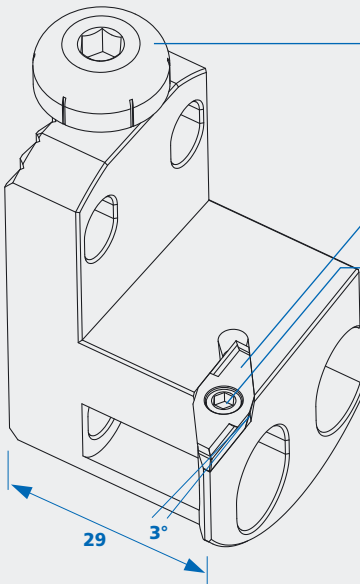

Höhenverstelle
screw to adjust the height
vis pour régler la hauteur
002.00.69

Wendeplatte
indexable insert
plaquette réversible
Applitec Typ 300

Senkschraube
counter sunk-head screw
vis à tête noyée
001.01.33

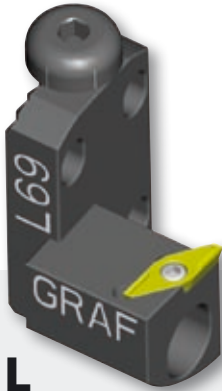

L
linksschneidend
cutting left
couper gauche

L69

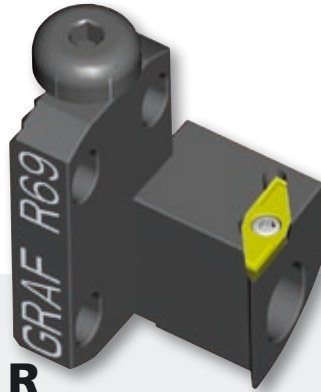

R
rechtsschneidend
cutting right
couper droit

R69

Anwendungsbereich **Langdrehen**
Application **turning**

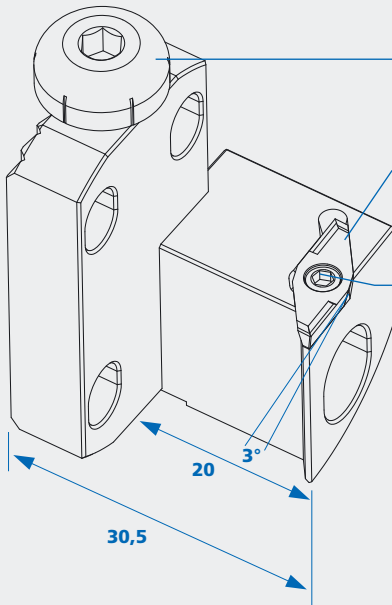

Höhenverstellungsschraube
screw to adjust the height
vis pour régler la hauteur
002.00.69

Wendeplatte
indexable insert
plaquette réversible
Applitec Typ 300

Senkschraube
counter sunk-head screw
vis à tête noyée
001.01.33

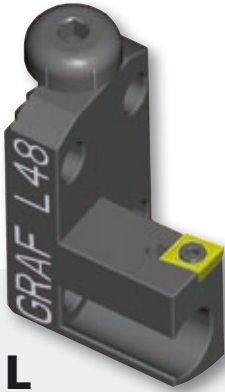

L

linksschneidend
cutting left
couper gauche

L48

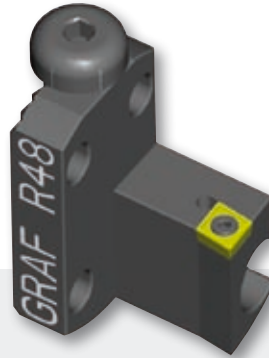

R

rechtsschneidend
cutting right
couper droit

R48

Anwendungsbereich **Langdrehen**
Application **turning**

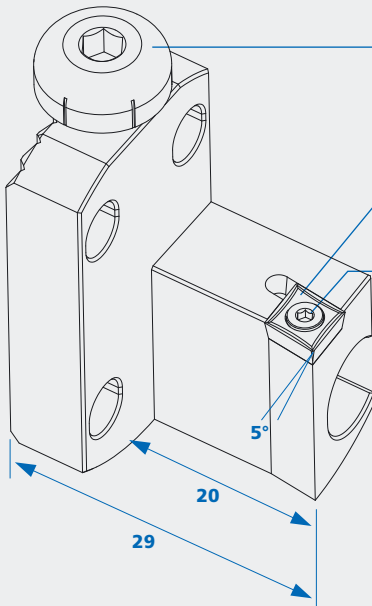

Höhenverstelle
screw to adjust the height
vis pour régler la hauteur
002.00.69

Wendeplatte
indexable insert
plaquette réversible
CC.. 06 02 ..

Senkschraube
counter sunk-head screw
vis à tête noyée
001.01.01

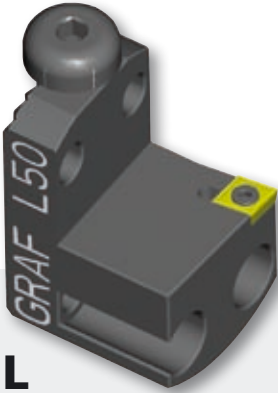

L

linksschneidend
cutting left
couper gauche

L50

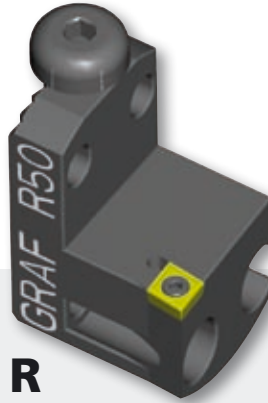

R

rechtsschneidend
cutting right
couper droit

R50

Anwendungsbereich **Langdrehen**
Application **turning**

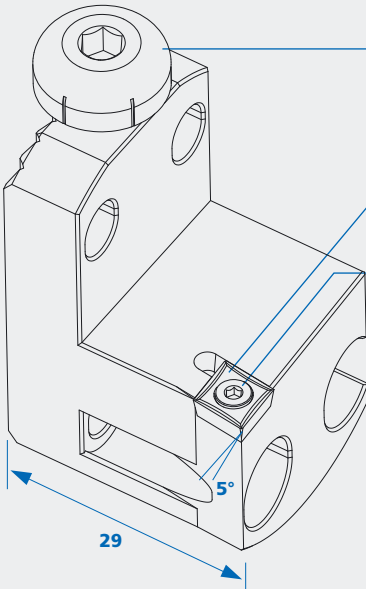

Höhenverstellungsschraube
screw to adjust the height
vis pour régler la hauteur
002.00.69

Wendeplatte
indexable insert
plaquette réversible
CC.. 06 02 ..

Senkschraube
counter sunk-head screw
vis à tête noyée
001.01.01



L

linksschneidend
cutting left
couper gauche

L36

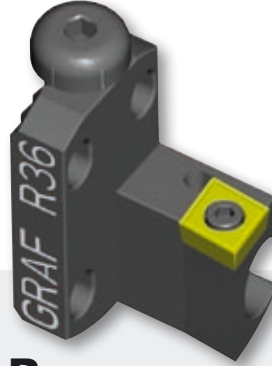

R

rechtsschneidend
cutting right
couper droit

R36

Anwendungsbereich **Langdrehen**
Application **turning**

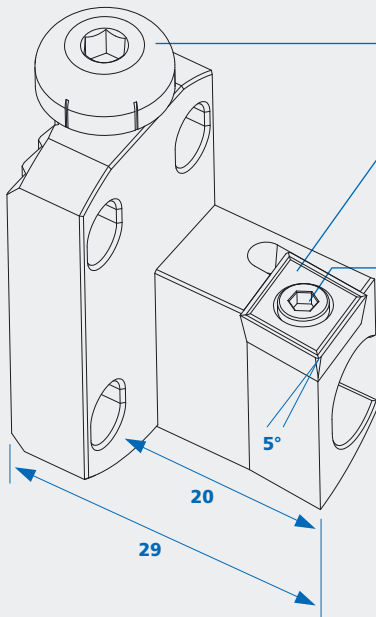

Höhenverstellungsschraube
screw to adjust the height
vis pour régler la hauteur
002.00.69

Wendeplatte
indexable insert
plaquette réversible
CC.. 09 T3 ..

Senkschraube
counter sunk-head screw
vis à tête noyée
001.01.15



L

linksschneidend
cutting left
couper gauche

L43IK

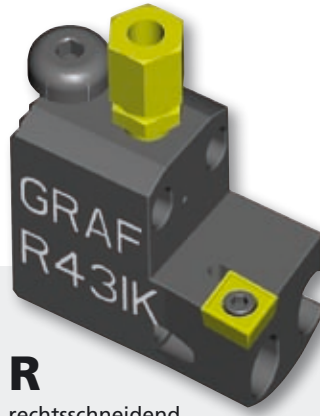

R

rechtsschneidend
cutting right
couper droit

R43IK

Anwendungsbereich **Langdrehen**
Application **turning**

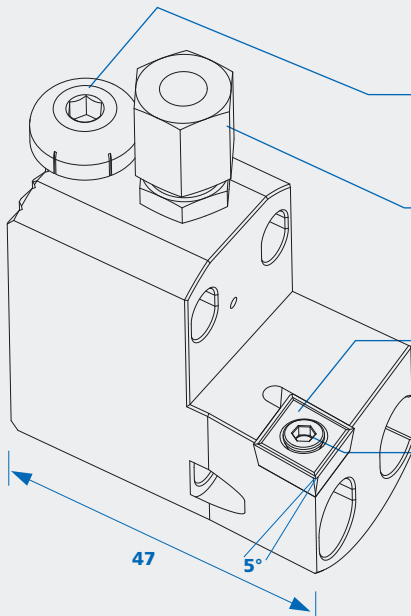

Höhenverstellungsschraube
screw to adjust the height
vis pour régler la hauteur
002.00.69

Kühlmittelanschluss
Coolant supply
Connexion pour liquide
de refroidissement
004.00.19

Wendepatte
indexable insert
plaquette réversible
CC.. 09 T3 ..

Senkschraube
counter sunk-head screw
vis à tête noyée
001.01.15

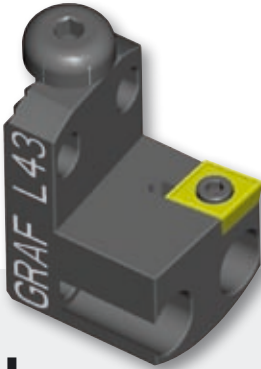

L

linksschneidend
cutting left
couper gauche

L43

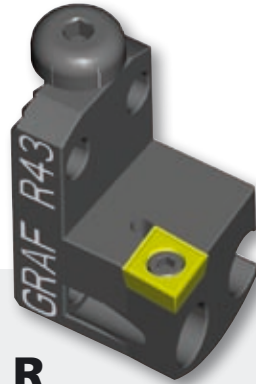

R

rechtsschneidend
cutting right
couper droit

R43

Anwendungsbereich **Langdrehen**
Application **turning**

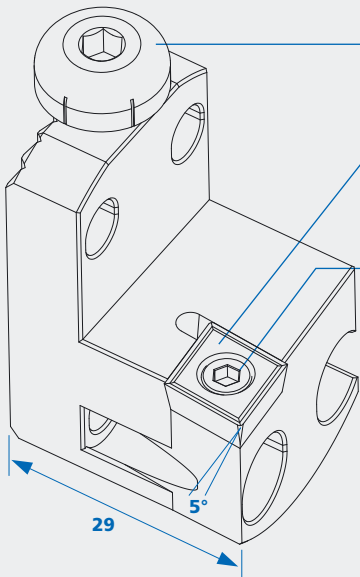

Höhenverstellungsschraube
screw to adjust the height
vis pour régler la hauteur

002.00.69

Wendeplatte
indexable insert
plaquette réversible

CC.. 09 T3 ..

Senkschraube
counter sunk-head screw
vis à tête noyée

001.01.15

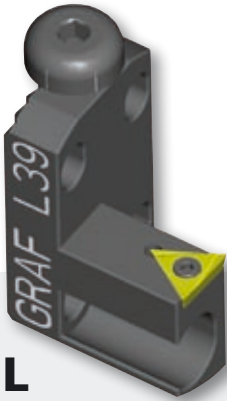

L

linksschneidend
cutting left
couper gauche

L39

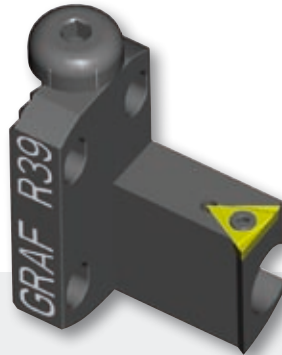

R

rechtsschneidend
cutting right
couper droit

R39

Anwendungsbereich **Langdrehen**
Application **turning**

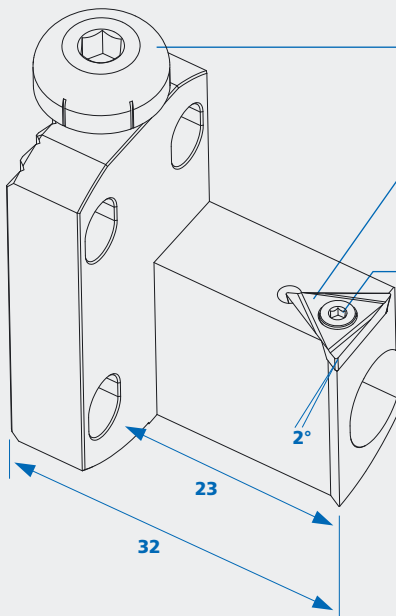

Höhenverstellungsschraube
screw to adjust the height
vis pour régler la hauteur
002.00.69

Wendeplatte
indexable insert
plaquette réversible
TC.. 11 02 ..

Senkschraube
counter sunk-head screw
vis à tête noyée
001.01.01

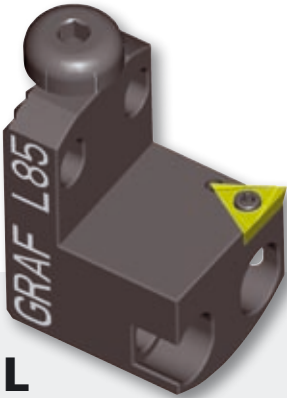

L
linksschneidend
cutting left
couper gauche

L85



R
rechtsschneidend
cutting right
couper droit

R85

Anwendungsbereich **Langdrehen**
Application **turning**

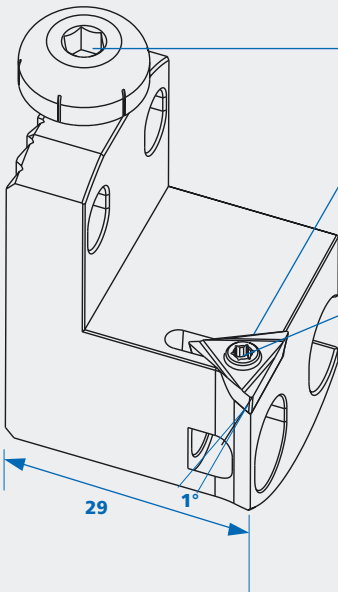

Höhenverstellungsschraube
screw to adjust the height
vis pour régler la hauteur
002.00.69

Wendeplatte
indexable insert
plaquette réversible
TC.. 11 03 ..

Senkschraube
counter sunk-head screw
vis à tête noyée
001.01.15



R

rechtsschneidend
cutting right
couper droit

R84

Anwendungsbereich **Langdrehen**
Application **turning**

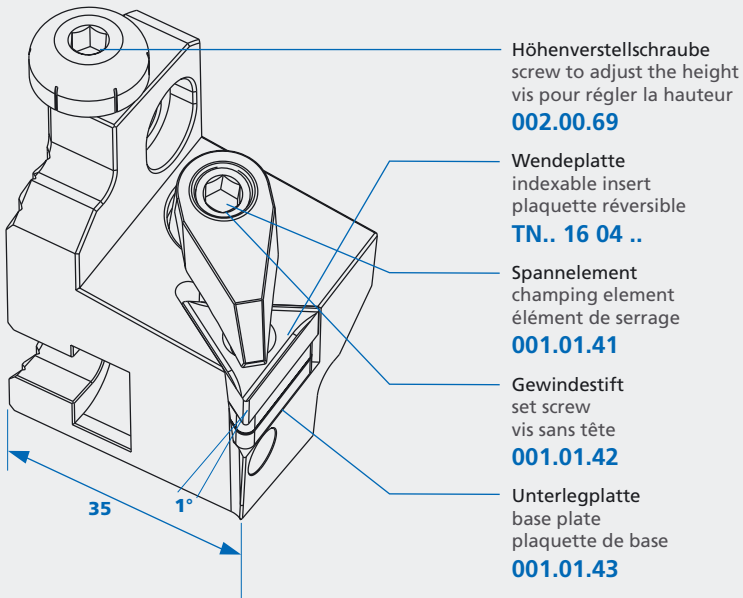



L

linksschneidend
cutting left
couper gauche

L03

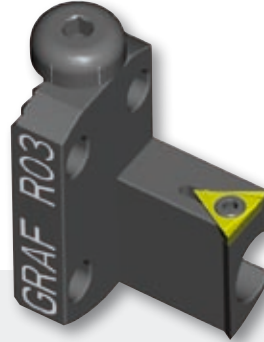

R

rechtsschneidend
cutting right
couper droit

R03

Anwendungsbereich **Langdrehen**
Application **turning**

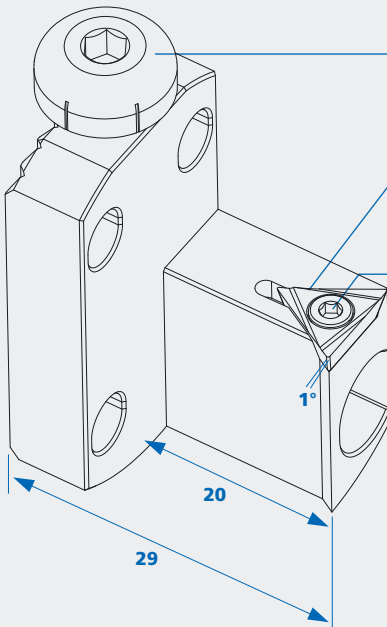

Höhenverstellungsschraube
screw to adjust the height
vis pour régler la hauteur
002.00.69

Wendeplatte
indexable insert
plaquette réversible
TP. 11 03 ..

Senkschraube
counter sunk-head screw
vis à tête noyée
001.01.07

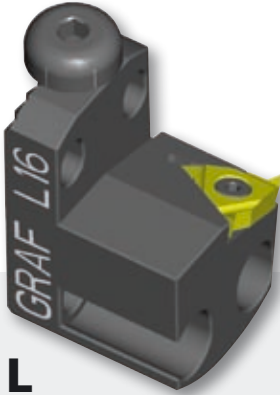

L

linksschneidend
cutting left
couper gauche

L16

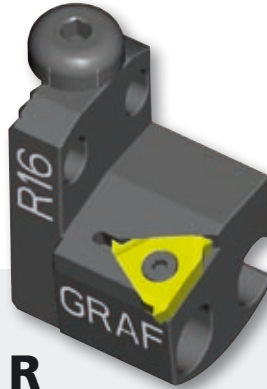

R

rechtsschneidend
cutting right
couper droit

R16

Anwendungsbereich **Gewindedrehen**
Application **threading**

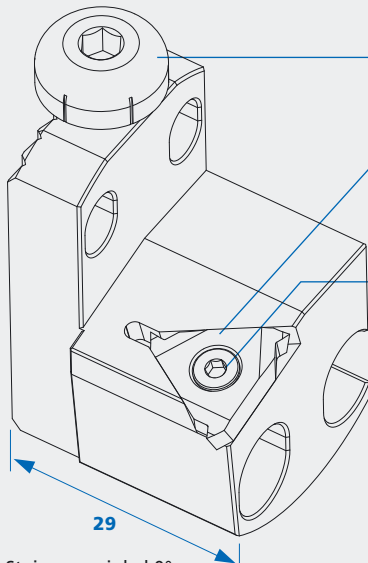

Steigungswinkel 0°
(Steigung max. 1,5)

Höhenverstellungsschraube
screw to adjust the height
vis pour régler la hauteur
002.00.69

Wendeplatte
indexable insert
plaquette réversible
ER 16.. /EL 16 ..

Senkschraube
counter sunk-head screw
vis à tête noyée
001.01.04

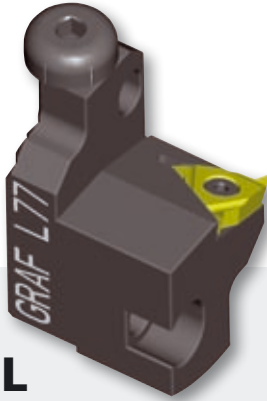

L

linksschneidend
cutting left
couper gauche

L77

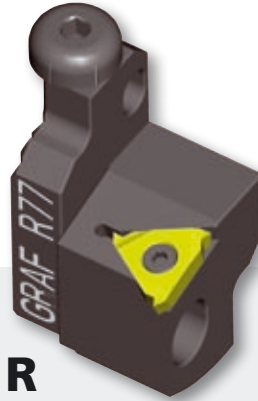

R

rechtsschneidend
cutting right
couper droit

R77



Anwendungsbereich **Gewindedrehen**
Application **threading**

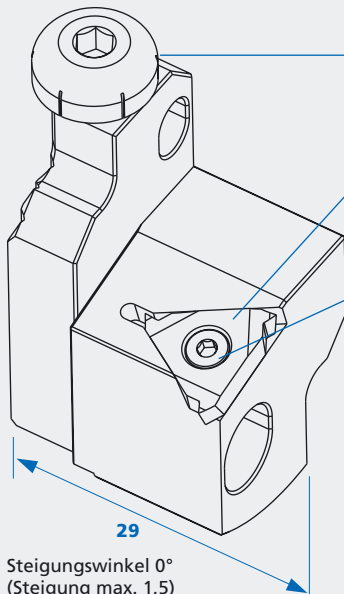

Höhenverstellungsschraube
screw to adjust the height
vis pour régler la hauteur
002.00.69

Wendeplatte
indexable insert
plaquette réversible
ER 16.. /EL 16 ..

Senkschraube
counter sunk-head screw
vis à tête noyée
001.01.04

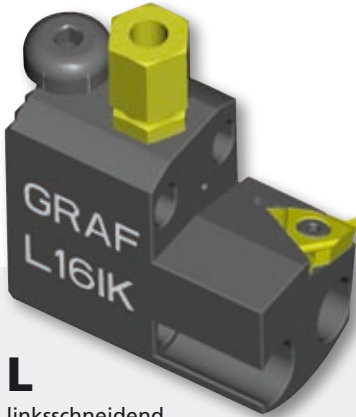

L

linksschneidend
cutting left
couper gauche

L16IK



R

rechtsschneidend
cutting right
couper droit

R16IK

Anwendungsbereich **Gewindedrehen**
Application **threading**

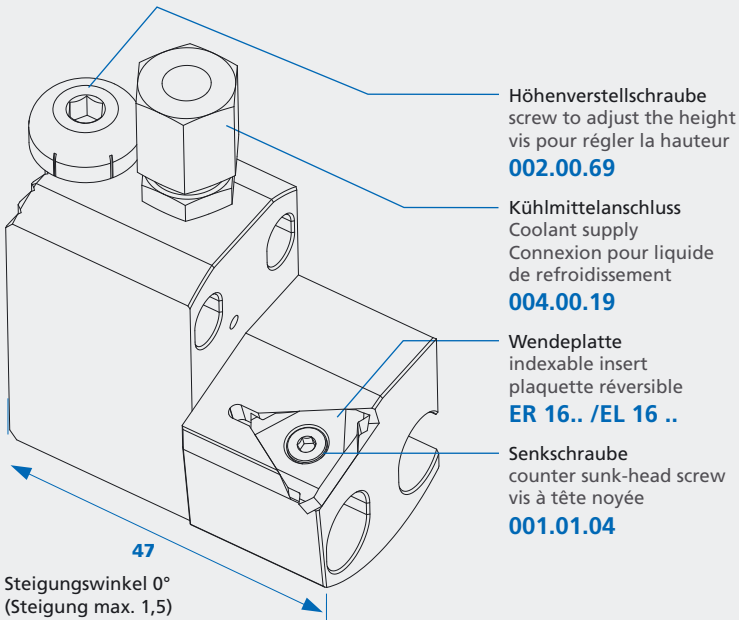

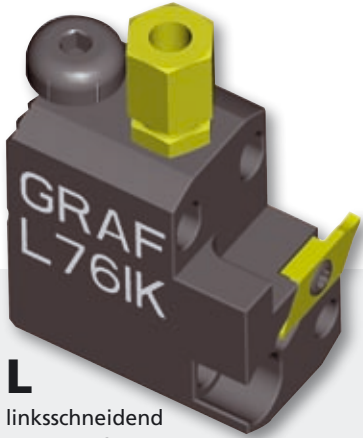

L

linksschneidend
cutting left
couper gauche

L76IK



R

rechtsschneidend
cutting right
couper droit

R76IK

Anwendungsbereich **Formstechen, Gewindestrehlen, Einstech-Langdrehen**
Application **forming, grooving, turning, threading**

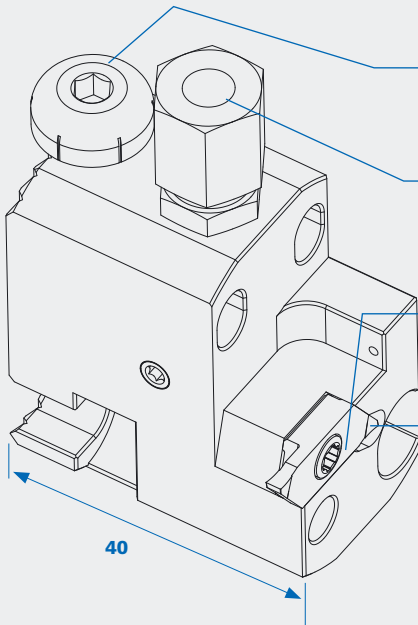

Höhenverstellungsschraube
screw to adjust the height
vis pour régler la hauteur
002.00.69

Kühlmittelanlasschluss
Coolant supply
Connexion pour liquide
de refroidissement
004.00.19

Senkschraube
counter sunk-head screw
vis à tête noyée
001.01.39

Wendeplatte
indexable insert
plaquette réversible
Horn Typ S274..

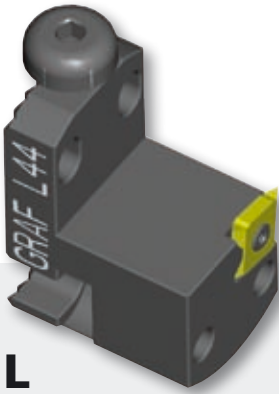

L

linksschneidend
cutting left
couper gauche

L44

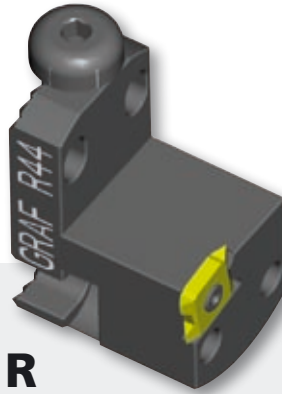

R

rechtsschneidend
cutting right
couper droit

R44

Anwendungsbereich **Gewindedrehen**
Application **threading**

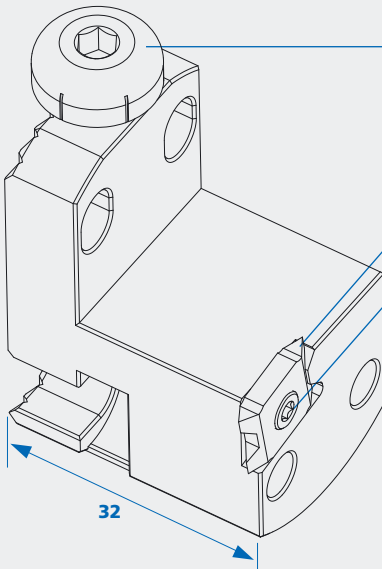

Höhenverstellungsschraube
screw to adjust the height
vis pour régler la hauteur
002.00.69

Wendeplatte
indexable insert
plaquette réversible
QER-12 .. (Quad-Cut)

Senkschraube
counter sunk-head screw
vis à tête noyée
001.01.07

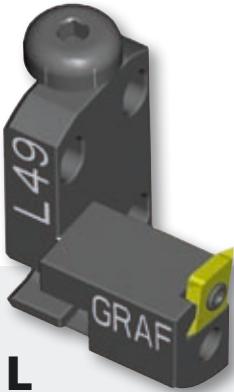

L

linksschneidend
cutting left
couper gauche

L49

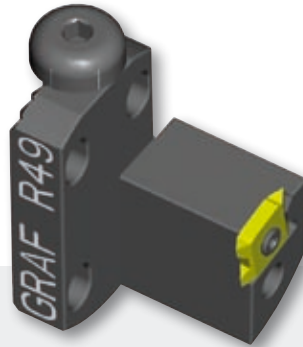

R

rechtsschneidend
cutting right
couper droit

R49

Anwendungsbereich **Gewindedrehen**
Application **threading**

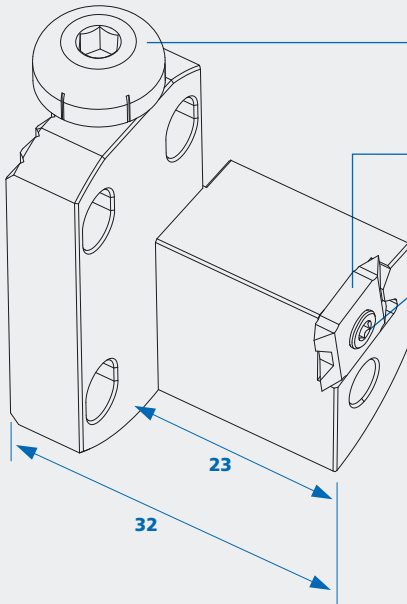

Höhenverstellungsschraube
screw to adjust the height
vis pour régler la hauteur
002.00.69

Wendeplatte
indexable insert
plaquette réversible
QER-12 .. (Quad-Cut)

Senkschraube
counter sunk-head screw
vis à tête noyée
001.01.07



L

linksschneidend
cutting left
couper gauche

L64IK



R

rechtsschneidend
cutting right
couper droit

R64IK

Anwendungsbereich **Formstechen, Gewindestrehlen, Einstech-Langdrehen**
Application **forming, grooving, turning, threading**

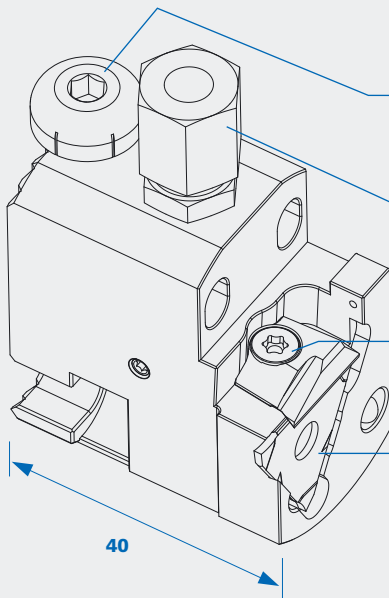

Höhenverstellungsschraube
screw to adjust the height
vis pour régler la hauteur
002.00.69

Kühlmittelsanschluss
Coolant supply
Connexion pour liquide
de refroidissement
004.00.19

Spannelement
clamping element
élément de serrage
4.081 (R) / 4.082 (L)

Wendeplatte
indexable insert
plaquette réversible
Horn Typ 312..

für Breite 0,5 bis 1,9
for width 0,5 - 1,9

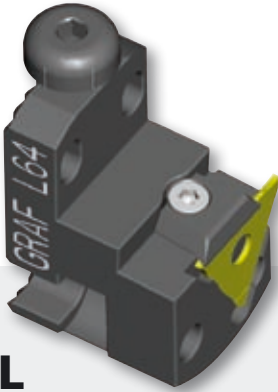

L

linksschneidend
cutting left
couper gauche

L64

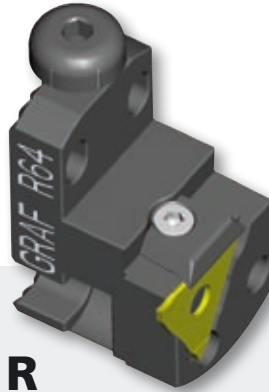

R

rechtsschneidend
cutting right
couper droit

R64

Anwendungsbereich **Formstechen, Gewindestrehlen, Einstech-Langdrehen**
Application **forming, grooving, turning, threading**

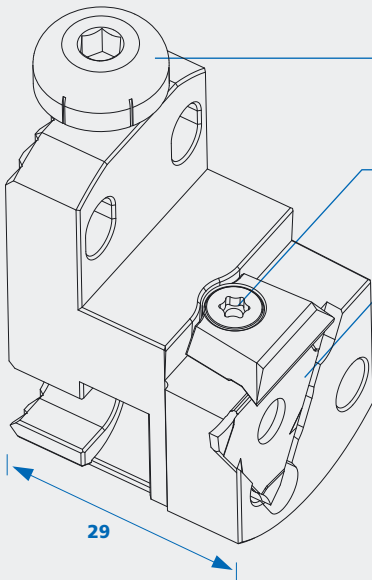

Höhenverstellungsschraube
screw to adjust the height
vis pour régler la hauteur
002.00.69

Spannelement
clamping element
élément de serrage
4.078

Wendeplatte
indexable insert
plaquette réversible
Horn Typ 312..

für Breite 0,5 bis 1,9
for width 0,5 - 1,9



L

linksschneidend
cutting left
couper gauche

L65IK



R

rechtsschneidend
cutting right
couper droit

R65IK

Anwendungsbereich **Formstechen, Gewindestrehlen, Einstech-Langdrehen**
Application **forming, grooving, turning, threading**

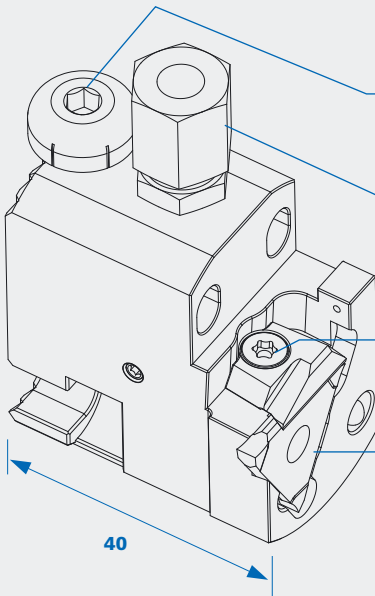

Höhenverstellungsschraube
screw to adjust the height
vis pour régler la hauteur

002.00.69

Kühlmittelanschluss
Coolant supply
Connexion pour liquide
de refroidissement

004.00.19

Spannelement
clamping element
élément de serrage

4.081 (R) / 4.082 (L)

Wendepatte
indexable insert
plaquette réversible
Horn Typ 312..

für Breite 1,9 bis 2,9
for width 1,9 - 2,9

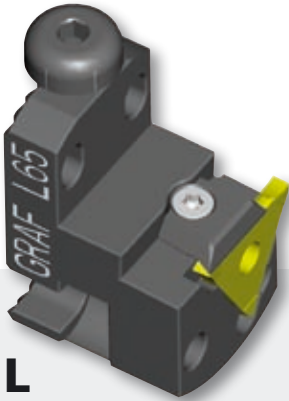

L

linksschneidend
cutting left
couper gauche

L65

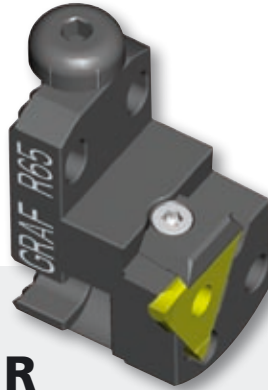

R

rechtsschneidend
cutting right
couper droit

R65

Anwendungsbereich **Formstechen, Gewindestrehlen, Einstech-Langdrehen**
Application **forming, grooving, turning, threading**

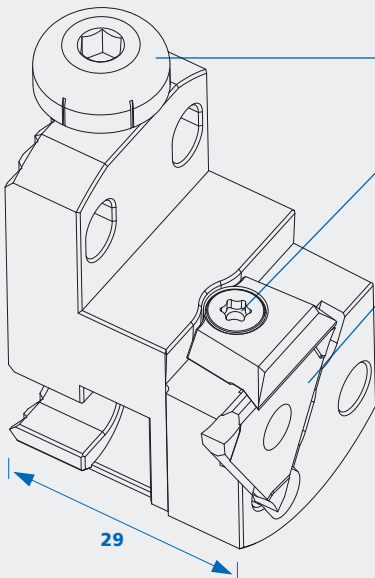

Höhenverstellungsschraube
screw to adjust the height
vis pour régler la hauteur
002.00.69

Spannelement
clamping element
élément de serrage
4.078

Wendeplatte
indexable insert
plaquette réversible
Horn Typ 312..

für Breite 1,9 bis 2,9
for width 1,9 - 2,9

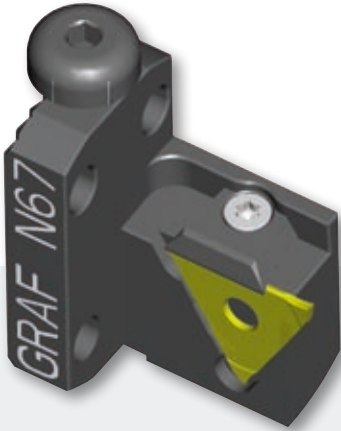

N67

Anwendungsbereich **Formstechen, Einstech-Langdrehen**
Application **forming, turning**

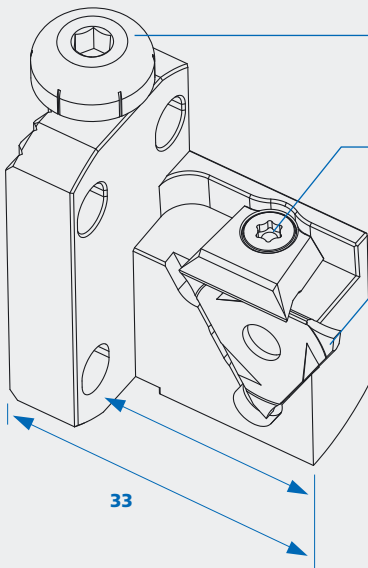

Höhenverstellungsschraube
screw to adjust the height
vis pour régler la hauteur
002.00.69

Spannelement
clamping element
élément de serrage
4.078

Wendeplatte
indexable insert
plaquette réversible
Horn Typ 312..

für Breite 0,5 bis 1,9
for width 0,5 - 1,9



N68

Anwendungsbereich **Formstechen, Gewindestreihen, Einstech-Langdrehen**
Application **forming, grooving, turning**

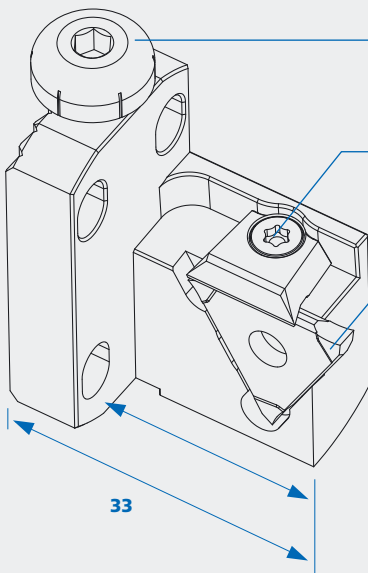

Höhenverstellungsschraube
screw to adjust the height
vis pour régler la hauteur
002.00.69

Spannelement
clamping element
élément de serrage
4.078

Wendeplatte
indexable insert
plaquette réversible
Horn Typ 312..

für Breite 1,9 bis 2,9
for width 1,9 - 2,9

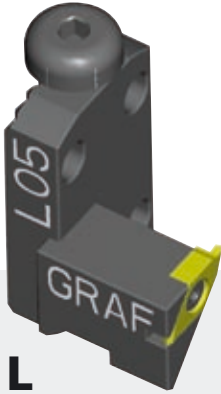

L

linksschneidend
cutting left
couper gauche

L05

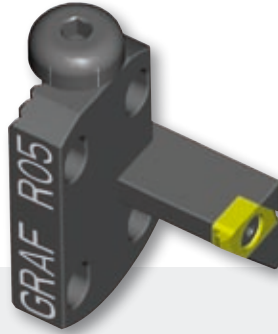

R

rechtsschneidend
cutting right
couper droit

R05

Anwendungsbereich **Formstechen, Gewindestreihen, Einstech-Langdrehen**
Range of application **profiling, threading, grooving**

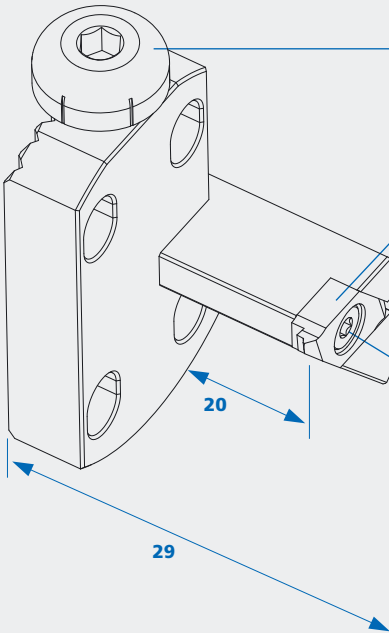

Höhenverstellungsschraube
screw to adjust the height
vis pour régler la hauteur
002.00.69

Wendepalette
indexable insert
plaquette réversible
SCD 08..
CSX 08..
CS 08..
VP CS 08..
TP CS 08..

Senkschraube
counter sunk-head screw
vis à tête noyée
001.01.04

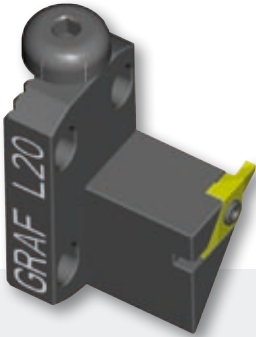

L

linksschneidend
cutting left
couper gauche

L20

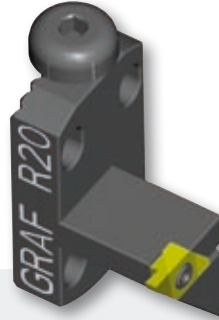

R

rechtsschneidend
cutting right
couper droit

R20

Anwendungsbereich **Formstechen, Gewindestreihen, Einstech-Langdrehen**
Application **forming, grooving, turning, threading**

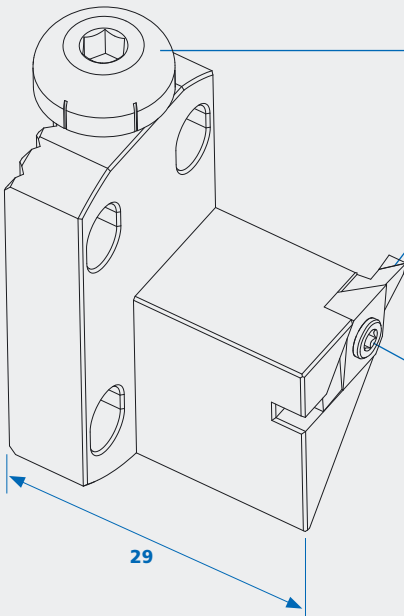

Höhenverstellungsschraube
screw to adjust the height
vis pour régler la hauteur
002.00.69

Wendeplatte
indexable insert
plaquette réversible
SCD 08...
CSX 08 ...
CS 08...
VP CS 08...
TP CS 08...

Senkschraube
counter sunk-head screw
vis à tête noyée
001.01.04

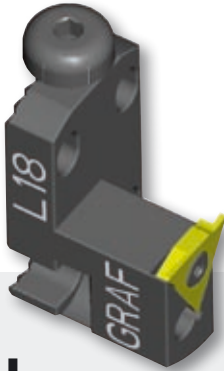

L

linksschneidend
cutting left
couper gauche

L18

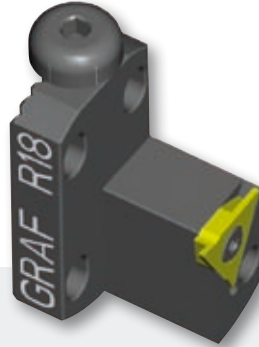

R

rechtsschneidend
cutting right
couper droit

R18

Anwendungsbereich

Formstechen, Gewindestrehlen, Einstech-Langdrehen, Kopierdrehen
Range of application **profiling, threading, grooving, copy turning**

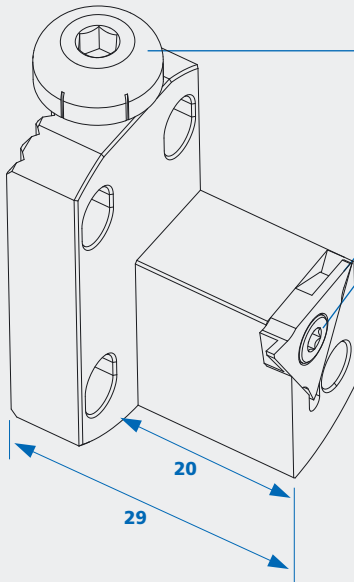

Höhenverstellungsschraube
screw to adjust the height
vis pour régler la hauteur
002.00.69

Wendeplatte
indexable insert
plaquette réversible
GTMH 32 ..

Senkschraube
counter sunk-head screw
vis à tête noyée
001.01.27

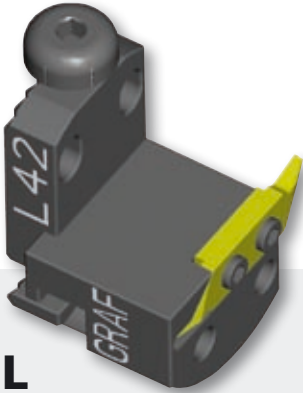

L

linksschneidend
cutting left
couper gauche

L42

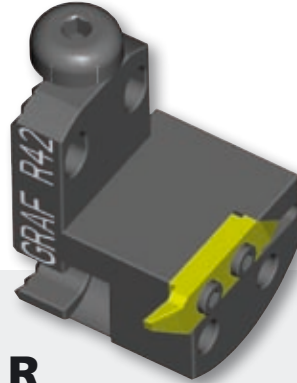

R

rechtsschneidend
cutting right
couper droit

R42

Anwendungsbereich

Formstechen, Gewindestrehlen, Einstech-Langdrehen, Kopierdrehen
Range of application **profiling, threading, grooving, copy turning**

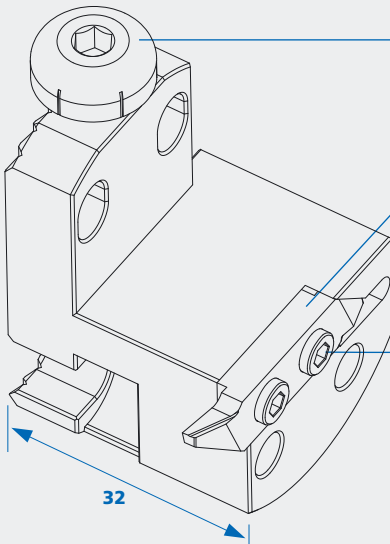

Höhenverstellungsschraube
screw to adjust the height
vis pour régler la hauteur
002.00.69

GRAF-Wendeplatte
GRAF indexable insert
GRAF plaquette réversible
G 02 ..
G 03 ..
G 04 ..
TP G 05/VP G 05

Senkschraube
counter sunk-head screw
vis à tête noyée
001.01.15

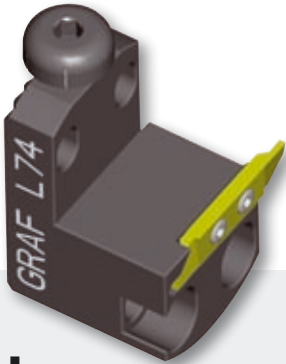

L

linksschneidend
cutting left
couper gauche

L74

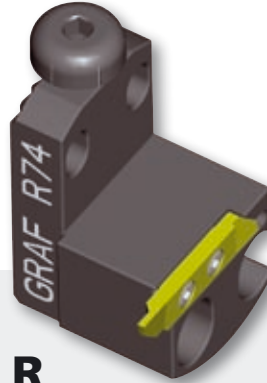

R

rechtsschneidend
cutting right
couper droit

R74



Anwendungsbereich **Formstechen, Gewindestrehlen, Einstech-Langdrehen**
Range of application **profiling, threading, grooving**

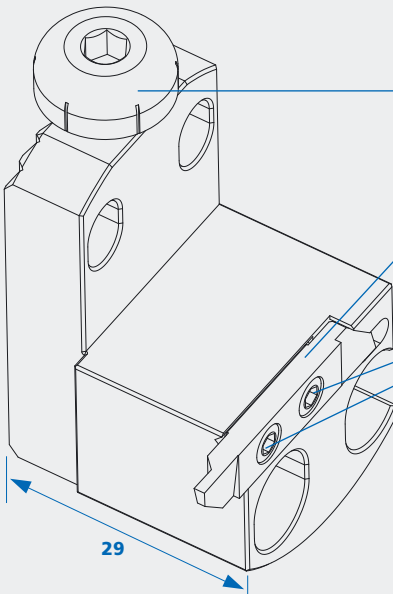

Höhenverstellungsschraube
screw to adjust the height
vis pour régler la hauteur

002.00.69

GRAF-Wendepalette
GRAF indexable insert
GRAF plaquette réversible

Für L Applitec Serie 730
Für R Applitec Serie 740

Senkschraube
counter sunk-head screw
vis à tête noyée

001.01.45

29

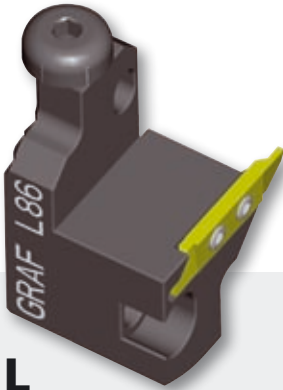

L

linksschneidend
cutting left
couper gauche

L86

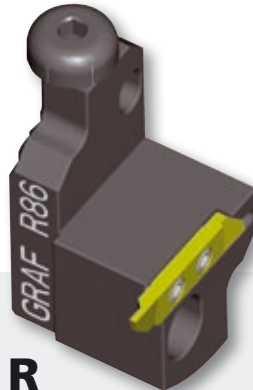

R

rechtsschneidend
cutting right
couper droit

R86

Anwendungsbereich **Formstechen, Gewindestrehlen, Einstech-Langdrehen**
Application **forming, grooving, turning, threading**

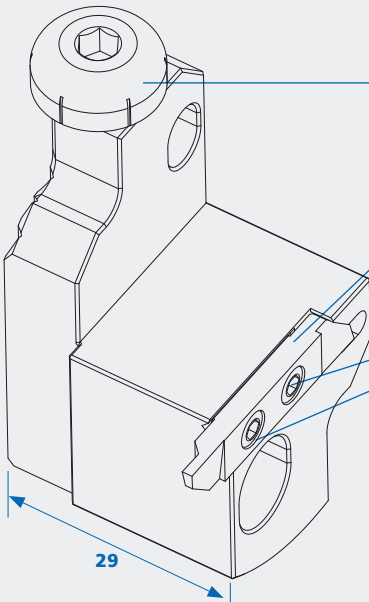

Höhenverstellungsschraube
screw to adjust the height
vis pour régler la hauteur
002.00.69

GRAF-Wendeplatte
GRAF indexable insert
GRAF plaquette réversible
Für L Applitec Serie 730
Für R Applitec Serie 740

Senkschraube
counter sunk-head screw
vis à tête noyée
001.01.45



N19IK

Anwendungsbereich **Axialdrehen**
Application **face grooving**

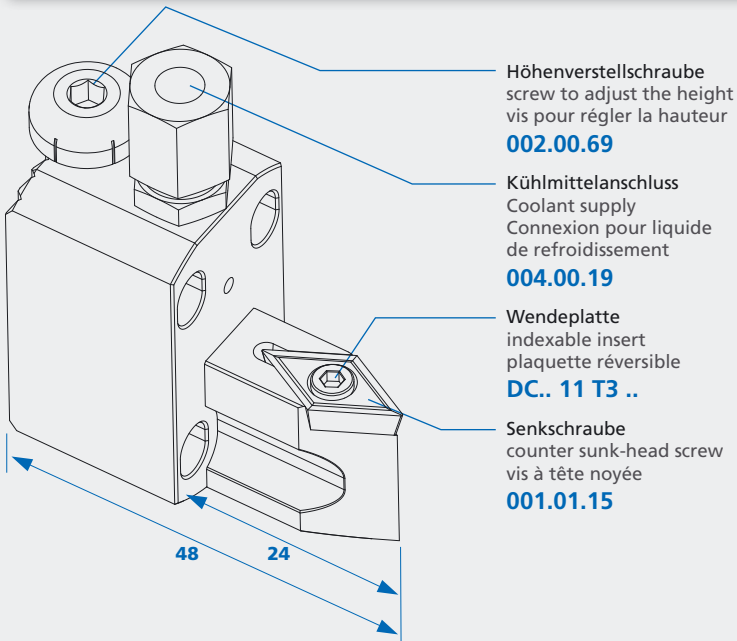

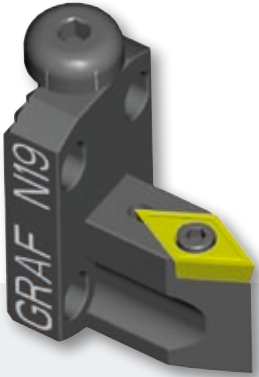

N19

Anwendungsbereich **Axialdrehen**
Application **face grooving**

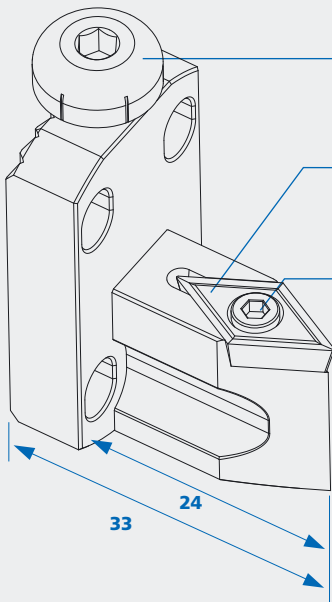

Höhenverstellungsschraube
screw to adjust the height
vis pour régler la hauteur
002.00.69

Wendeplatte
indexable insert
plaquette réversible
DC.. 11 T3 ..

Senkschraube
counter sunk-head screw
vis à tête noyée
001.01.15



N38IK

Anwendungsbereich **Axialdrehen**
Application **face grooving**

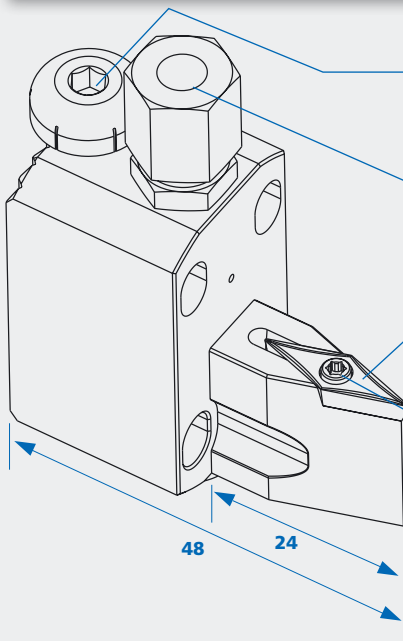

Höhenverstellungsschraube
screw to adjust the height
vis pour régler la hauteur
002.00.69

Kühlmittelanschluss
Coolant supply
Connexion pour liquide
de refroidissement
004.00.19

Wendepatte
indexable insert
plaquette réversible
VC.. 11 03 ..

Senkschraube
counter sunk-head screw
vis à tête noyée
001.01.15



N38

Anwendungsbereich **Axialdrehen**
Application **face grooving**

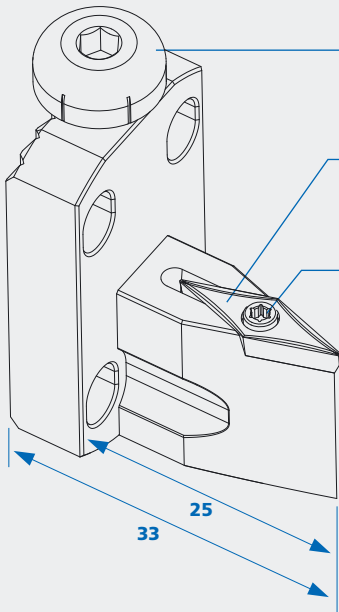

Höhenverstellungsschraube
screw to adjust the height
vis pour régler la hauteur
002.00.69

Wendeplatte
indexable insert
plaquette réversible
VC.. 11 03 ..

Senkschraube
counter sunk-head screw
vis à tête noyée
001.01.08



L

linksschneidend
cutting left
couper gauche

L29

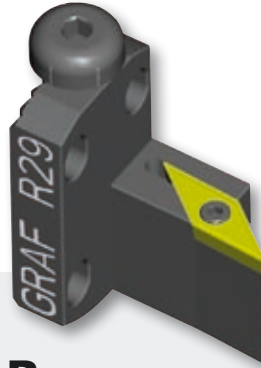

R

rechtsschneidend
cutting right
couper droit

R29

Anwendungsbereich **Axialdrehen**
Application **face grooving**

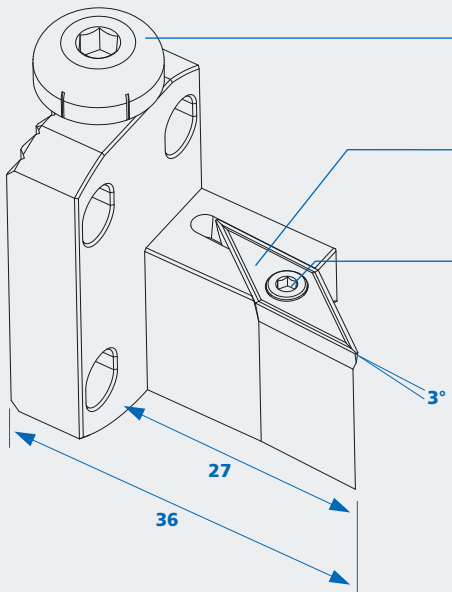

Höhenverstellungsschraube
screw to adjust the height
vis pour régler la hauteur
002.00.69

Wendepatte
indexable insert
plaquette réversible
VC..13 03...

Senkschraube
counter sunk-head screw
vis à tête noyée
001.01.07



L

linksschneidend
cutting left
couper gauche

L97

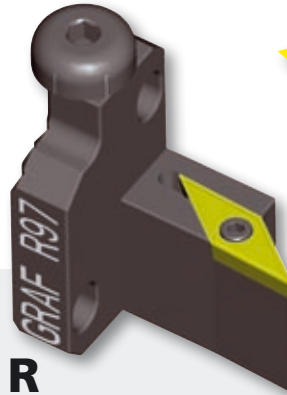

R

rechtsschneidend
cutting right
couper droit

R97

Anwendungsbereich **Axialdrehen**
Application **face grooving**

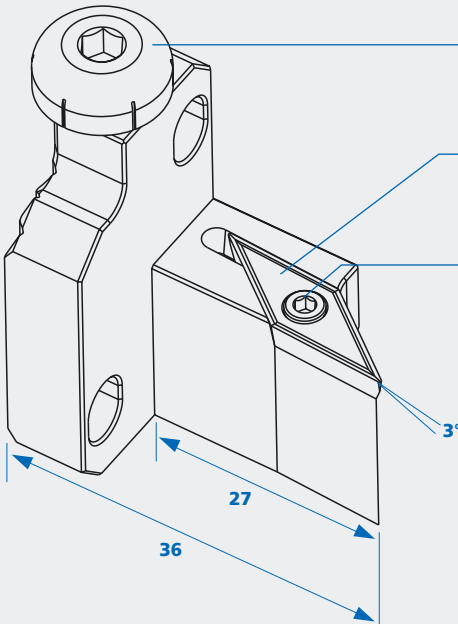

Höhenverstellungsschraube
screw to adjust the height
vis pour régler la hauteur
002.00.69

Wendeplatte
indexable insert
plaquette réversible
VC.. 13 03 ..

Senkschraube
counter sunk-head screw
vis à tête noyée
001.01.07

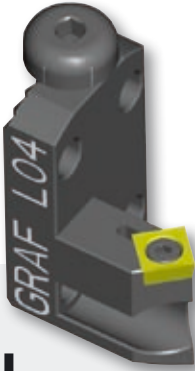

L

linksschneidend
cutting left
couper gauche

L04



R

rechtsschneidend
cutting right
couper droit

R04

Anwendungsbereich **Axialdrehen**
Application **face grooving**

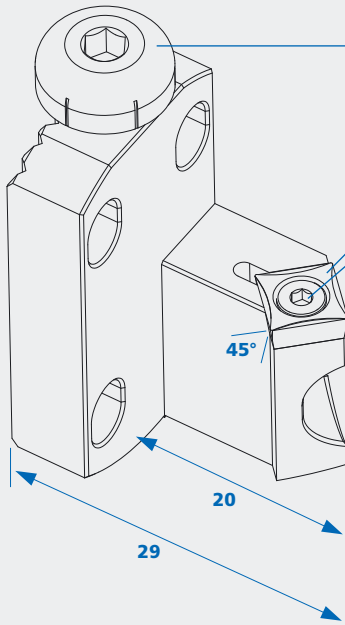

Höhenverstellungsschraube
screw to adjust the height
vis pour régler la hauteur
002.00.69

Wendeplatte
indexable insert
plaquette réversible
SC.. 07 03 ..

Senkschraube
counter sunk-head screw
vis à tête noyée
001.01.04

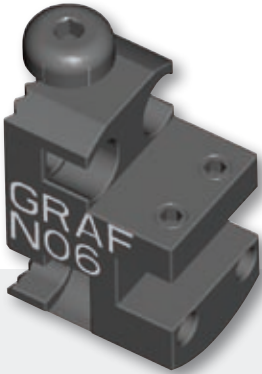

N06

Anwendungsbereich **Rückseitenbearbeitung für Vierkantschaft 10 X 10**
Application **back working for square shank 10 x 10**

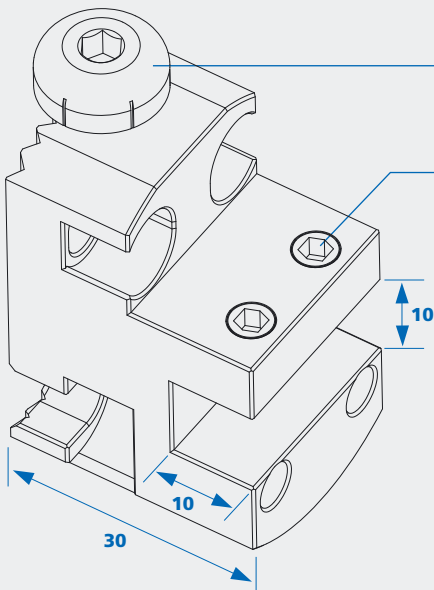

Höhenverstellungsschraube
screw to adjust the height
vis pour régler la hauteur
002.00.69

Gewindestift
set screw
vis sans tête
002.00.11

**Höheneinstell-Vorrichtung
für Rückseitenbearbeitungs Drehhalter HVR 40**

Device for height adjusting
for back working holder HVR 40

Appareil de réglage en hauteur
pour outils à usinage revers HVR 40

	d1	d2
STAR	16	22
CITIZEN	3/4"	1"
MAIER	30	34
HANWHA	20 25	28 33

weitere Abmessungen auf Anfrage
Please ask us for other dimensions
Autres dimensions disponibles sur demande

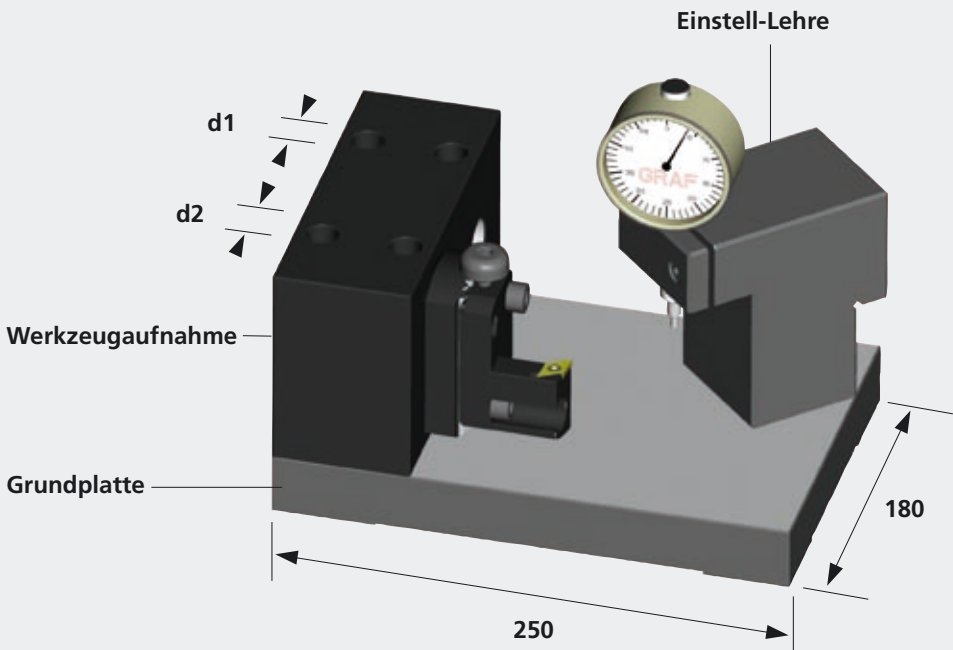



**Das GRAF-
Werkzeugprogramm
mit Innenkühlung.**
Fordern Sie die neue-
sten Unterlagen an!

**The GRAF-Tool
program with
interior cooling.**
Ask for the latest
documents!

**Le programme
d'outillage à
refroidissement de
Graf.**
Demandez nos
nouveaux prospectus!

